

644 G

Wheel Loader



JOHN DEERE



A yellow John Deere 644 G-tier wheel loader is shown in action, dumping a large quantity of gravel. The machine is positioned on a pile of gravel, and a large plume of dust and gravel is being discharged from the bucket. The background is a clear blue sky with some bare trees in the distance. The John Deere logo is visible on the side of the machine.

644 G-TIER WHEEL LOADER

NO NONSENSE.

The dependable, economical 644 G-tier is all business. From stockpiling and truck or hopper loading, to short load-and-carry tasks and material handling, this mid-size wheel loader's got you covered. Its lower initial acquisition cost doesn't mean you have to sacrifice quality and support. The 644 G-tier delivers the rugged reliability and ease of operation you expect from John Deere — a company with over a half-century of experience designing and manufacturing exceptional wheel loaders.



RELIABLE

+



SIMPLE TO SERVICE

FEATURES

Proven design and reliability

The John Deere 644 G-tier leverages components and technology featured in both our current and former series loaders for decades. Powertrain, hydraulic, and electrical systems are the culmination of thousands of hours of proven experience in the field.

Minimal maintenance and operating costs

Extended service intervals plus parts and fluid costs over 12,000 hours of usage are as much as 14-percent lower than the nearest competitor.*

Peace of mind

Renowned John Deere and dealer support, parts availability, and warranty help keep customers up and running.

*Based on manufacturer's required scheduled maintenance events through 12,000 hours of service as of August 2020. Calculated using August 2020 manufacturer's suggested list pricing for OEM parts and fluids in U.S. dollars. Labor costs not included.

FIND YOUR FIT



LEADING EDGE

Premium edge with innovative technology



EXCEPTIONAL PERFORMANCE

Advanced features and performance



RUGGED AND RELIABLE

Proven capabilities and value



Streamlined servicing

All daily service points including fuel are conveniently grouped on the left side of the machine at ground level, for easy access. Hinged doors provide wide-open access to the engine, the cooling system, and other components. Cooling package is isolated from the engine compartment, so the fan pulls fresh air that is not preheated through the coolers.

Maximize jobsite versatility

In addition to current P- and X-tier options, the coupler accepts buckets and attachments dating to K-Series Loaders to help maximize machine utilization and fleet versatility.

Cab comfort

Roomy cab features ergonomically placed joystick controls, foot pedals, and sealed-switch module. Seat-mounted right-hand joystick includes integrated F-N-R switch. Optional air-ride seat increases the level of operator comfort.

User-friendly control

The 644 G-tier features common controls that will be familiar to both novice and experienced operators. Optional front-differential lock provides additional traction in muddy or loose-material conditions. Pilot controls are intuitive to operate. In-cab adjustable boom-height kickout and return to carry as well as return to dig can be easily activated from the convenient touchpad, speeding production in repetitive applications.



644 G-TIER WHEEL LOADER

Remote diagnostics and support

To maximize uptime and lower costs, JDLink™ connectivity provides machine location, utilization data, and alerts to help you maximize productivity and efficiency. JDLink also enables John Deere Connected Support™. Dealers use Expert Alerts based on data from thousands of connected machines to proactively address conditions that may otherwise likely lead to downtime. Your dealer can also monitor machine health and leverage remote diagnostics and programming capability to further diagnose problems and even update machine software without a time-consuming trip to the jobsite.*

*Availability varies by region. Options not available in every country.



Keep free of debris

Optional programmable fan automatically reverses at predetermined intervals to keep coolers clean throughout the day. Or run individual cleaning cycles through the monitor.

644 G-TIER WHEEL LOADER SPECIFICATIONS

While general information, pictures, and descriptions are provided, some illustrations and text may include product options and accessories NOT AVAILABLE in all regions, and in some countries products and accessories may require modifications or additions to ensure compliance with the local regulations of those countries.

Engine	644 G Z-BAR TIER 2		644 G Z-BAR TIER 3		644 G Z-BAR FINAL TIER 4 (FT4)	
Manufacturer and Model	John Deere PowerTech™ 6068H		John Deere PowerTech™ Plus 6068H		John Deere PowerTech™ PVS 6068H	
Non-Road Emission Standard	EPA Tier 2/EU Stage II		EPA Tier 3/EU Stage IIIA		EPA FT4/EU Stage V	
Cylinders	6		6		6	
Valves Per Cylinder	4		4		4	
Displacement	6.8 L (414 cu. in.)		6.8 L (414 cu. in.)		6.8 L (414 cu. in.)	
Net Peak Power (ISO 9249)	175 kW (235 hp) at 1,700 rpm		185 kW (248 hp) at 1,800 rpm		169 kW (227 hp) at 1,800 rpm	
Net Peak Torque (ISO 9249)	1024 Nm (755 lb.-ft.) at 1,400 rpm		1024 Nm (755 lb.-ft.) at 1,400 rpm		981 Nm (724 lb.-ft.) at 1,400 rpm	
Net Torque Rise	55%		42%		66%	
Fuel System (electronically controlled)	High-pressure common rail		High-pressure common rail		High-pressure common rail	
Lubrication	Full-flow spin-on filter and integral cooler		Full-flow spin-on filter and integral cooler		Full-flow spin-on filter and integral cooler	
Aspiration	Turbocharged, charge air cooled		Turbocharged, charge air cooled		Turbocharged, charge air cooled	
Air Cleaner	Under-hood, dual-element dry type, restriction indicator in cab monitor for service		Under-hood, dual-element dry type, restriction indicator in cab monitor for service		Under-hood, dual-element dry type, restriction indicator in cab monitor for service	
Cooling	644 G Z-BAR TIER 2 / TIER 3 / FT4					
Fan Drive	Hydraulically driven, proportionally controlled, fan aft of coolers					
Electrical	644 G Z-BAR TIER 2		644 G Z-BAR TIER 3		644 G Z-BAR FT4	
Electrical System	24 volt with 80-amp alternator		24 volt with 80-amp alternator		24 volt with 100-amp alternator	
Batteries (2 – 12 volt)	950 CCA (each)		950 CCA (each)		950 CCA (each)	
Transmission System						
Type	Countershaft-type PowerShift™		Countershaft-type PowerShift		Countershaft-type PowerShift	
Torque Converter	Single stage, single phase		Single stage, single phase		Single stage, single phase	
Shift Control	Electronically modulated, adaptive, load and speed dependent		Electronically modulated, adaptive, load and speed dependent		Electronically modulated, adaptive, load and speed dependent	
Operator Interface	Joystick-mounted F-N-R; Quick-Shift button on hydraulic lever		Joystick-mounted F-N-R; Quick-Shift button on hydraulic lever		Joystick-mounted F-N-R; Quick-Shift button on hydraulic lever	
Shift Modes	Manual/auto (1st-D or 2nd-D); Quick-Shift button with 2 selectable modes: kick-down or kick-up/down; and 3 adjustable clutch cutoff settings					
	<i>4-Speed</i>		<i>4-Speed</i>		<i>4-Speed</i>	
Maximum Travel Speeds (with 23.5 R 25 tires)	<i>Forward</i>	<i>Reverse</i>	<i>Forward</i>	<i>Reverse</i>	<i>Forward</i>	<i>Reverse</i>
Range 1	7.1 km/h (4.4 mph)	7.5 km/h (4.7 mph)	7.1 km/h (4.4 mph)	7.5 km/h (4.7 mph)	7.1 km/h (4.4 mph)	7.5 km/h (4.7 mph)
Range 2	11.8 km/h (7.3 mph)	12.5 km/h (7.7 mph)	11.8 km/h (7.3 mph)	12.5 km/h (7.7 mph)	11.8 km/h (7.3 mph)	12.5 km/h (7.7 mph)
Range 3	23.5 km/h (14.6 mph)	24.8 km/h (15.4 mph)	23.2 km/h (14.4 mph)	24.5 km/h (15.2 mph)	23.4 km/h (14.5 mph)	24.6 km/h (15.3 mph)
Range 4	37.9 km/h (23.6 mph)	N/A	38.7 km/h (24.0 mph)	N/A	37.6 km/h (23.3 mph)	N/A
Axles/Brakes	644 G Z-BAR TIER 2 / TIER 3 / FT4					
Final Drives	Heavy-duty inboard-mounted planetary					
Differentials	Open differential, locking front optional					
Rear Axle Oscillation, Stop to Stop (with 23.5 R 25 tires)	26 deg. (13 deg. each direction)					
Brakes (conform to ISO 3450)						
Service	Hydraulically actuated, spring retracted, self-adjusting, inboard sun-shaft mounted, oil cooled, single disc					
Parking	Automatic spring applied, hydraulically released, driveline mounted, oil cooled, multi disc					
Tires/Wheels (see pages 9–10 for complete tire adjustments)	644 G Z-BAR TIER 2		644 G Z-BAR TIER 3		644 G Z-BAR FT4	
	<i>Tread Width</i>	<i>Width Over Tires</i>	<i>Tread Width</i>	<i>Width Over Tires</i>	<i>Tread Width</i>	<i>Width Over Tires</i>
Linglong 23.5-25 TL, E3/L3, 16PR Bias Tire	2170 mm (85.4 in.)	2765 mm (108.9 in.)	2170 mm (85.4 in.)	2765 mm (108.9 in.)	N/A	N/A
TianLi 23.5 R25, 2 Star TUL300 (E3/L3), TL Radial Tire	N/A	N/A	N/A	N/A	2170 mm (85.4 in.)	2777 mm (109.3 in.)
Serviceability	644 G Z-BAR TIER 2 / TIER 3 / FT4					
Refill Capacities						
Fuel Tank (with lockable cap)	300 L (79.3 gal.)		300 L (79.3 gal.)		300 L (79.3 gal.)	
Diesel Exhaust Fluid (DEF)	N/A		N/A		15.6 L (16.5 qt.)	
Cooling System, Engine	30 L (31.7 qt.)		30 L (31.7 qt.)		34 L (35.9 qt.)	
Engine Oil With Vertical Spin-On Filter	21 L (22.2 qt.)		21 L (22.2 qt.)		19.5 L (20.6 qt.)	
Transmission Reservoir With Vertical Filter	25 L (26.4 qt.)		25 L (26.4 qt.)		30 L (31.7 qt.)	
Axle Oil (front and rear, each)	25 L (26.4 qt.)		25 L (26.4 qt.)		25 L (26.4 qt.)	
Hydraulic Reservoir and Filter	100 L (26.4 gal.)		100 L (26.4 gal.)		100 L (26.4 gal.)	
Park Brake Oil (wet disc)	0.65 L (22 oz.)		0.65 L (22 oz.)		0.65 L (22 oz.)	
Hydraulic System/Steering						
Pump (loader and steering)	Variable-displacement, axial-piston pump; closed-center, pressure-compensating system					
Maximum Rated Flow at 3000 kPa (435 psi) and 2,250 rpm	330 L/m (87 gpm)					
System Relief Pressure (loader and steering)	23 100 kPa (3,350 psi)					

644 G-TIER WHEEL LOADER SPECIFICATIONS

644

G

While general information, pictures, and descriptions are provided, some illustrations and text may include product options and accessories NOT AVAILABLE in all regions, and in some countries products and accessories may require modifications or additions to ensure compliance with the local regulations of those countries.

Hydraulic System/Steering (continued) 644 G Z-BAR TIER 2 / TIER 3 / FT4

Loader Controls 2-function valve; joystick control or fingertip controls (field kit); hydraulic-function enable/disable; optional 3rd-function valve with auxiliary lever

Steering (conforms to ISO 5010)

Type Power, fully hydraulic

Articulation Angle 80-deg. arc (40 deg. each direction)

Turning Radius (measured to centerline of outside tire) 5.55 m (18 ft. 3 in.)

Hydraulic Cycle Times

Raise 5.2 sec.

Dump 1.5 sec.

Lower (power down) 3.2 sec.

Total 9.9 sec.

Bucket Capacity Range

Bucket Type

Pin-On 3.1–3.20 m³ (4.0–4.25 cu. yd.)

Coupler 3.1 m³ (4.0 cu. yd.)

Dimensions and Specifications With Pin-On Bucket With Bolt-On Edge

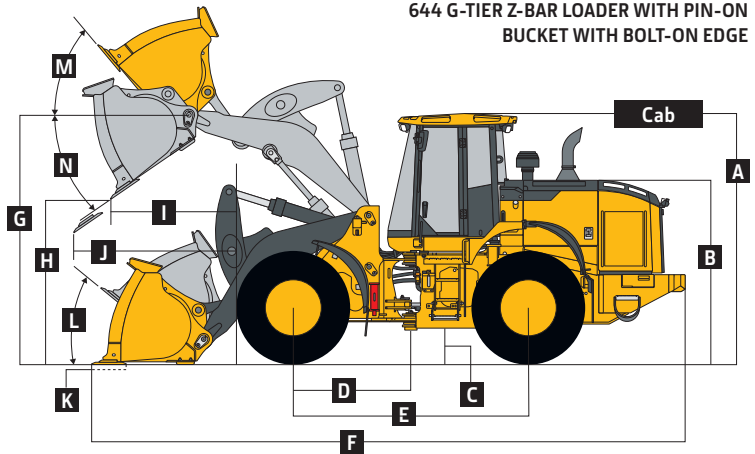

644 G-TIER Z-BAR LOADER WITH PIN-ON BUCKET WITH BOLT-ON EDGE

Dimensions With Bucket With Bolt-On Edge (illustration above right)	644 G Z-Bar Tier 2		644 G Z-Bar Tier 3		644 G Z-Bar FT4	
	3.10-m ³ (4.00 cu. yd.) general-purpose	3.20-m ³ (4.25 cu. yd.) general-purpose	3.10-m ³ (4.00 cu. yd.) general-purpose	3.20-m ³ (4.25 cu. yd.) general-purpose	3.10-m ³ (4.00 cu. yd.) general-purpose	3.20-m ³ (4.25 cu. yd.) general-purpose
A Height to Top of Cab	3.46 m (11 ft. 4 in.)	3.46 m (11 ft. 4 in.)	3.46 m (11 ft. 4 in.)	3.46 m (11 ft. 4 in.)	3.46 m (11 ft. 4 in.)	3.46 m (11 ft. 4 in.)
B Hood Height	2.63 m (8 ft. 8 in.)	2.63 m (8 ft. 8 in.)	2.63 m (8 ft. 8 in.)	2.63 m (8 ft. 8 in.)	2.63 m (8 ft. 8 in.)	2.63 m (8 ft. 8 in.)
C Ground Clearance	422 mm (16.6 in.)	422 mm (16.6 in.)	422 mm (16.6 in.)	422 mm (16.6 in.)	422 mm (16.6 in.)	422 mm (16.6 in.)
D Length From Centerline to Front Axle	1.60 m (5 ft. 3 in.)	1.60 m (5 ft. 3 in.)	1.60 m (5 ft. 3 in.)	1.60 m (5 ft. 3 in.)	1.60 m (5 ft. 3 in.)	1.60 m (5 ft. 3 in.)
E Wheelbase	3.26 m (10 ft. 8 in.)	3.26 m (10 ft. 8 in.)	3.26 m (10 ft. 8 in.)	3.26 m (10 ft. 8 in.)	3.26 m (10 ft. 8 in.)	3.26 m (10 ft. 8 in.)
F Overall Length, Bucket on Ground	8.08 m (26 ft. 6 in.)	8.17 m (26 ft. 10 in.)	8.08 m (26 ft. 6 in.)	8.17 m (26 ft. 10 in.)	8.08 m (26 ft. 6 in.)	8.17 m (26 ft. 10 in.)
G Height to Hinge Pin, Fully Raised	4.13 m (13 ft. 7 in.)	4.13 m (13 ft. 7 in.)	4.13 m (13 ft. 7 in.)	4.13 m (13 ft. 7 in.)	4.13 m (13 ft. 7 in.)	4.13 m (13 ft. 7 in.)
H Dump Clearance, 45 deg., Full Height	2.98 m (9 ft. 9 in.)	2.92 m (9 ft. 7 in.)	2.98 m (9 ft. 9 in.)	2.92 m (9 ft. 7 in.)	2.98 m (9 ft. 9 in.)	2.92 m (9 ft. 7 in.)
I Reach, 45-deg. Dump, Full Height	1.01 m (3 ft. 4 in.)	1.06 m (3 ft. 6 in.)	1.01 m (3 ft. 4 in.)	1.06 m (3 ft. 6 in.)	1.01 m (3 ft. 4 in.)	1.06 m (3 ft. 6 in.)
J Reach, 45-deg. Dump, 2.13-m (7 ft. 0 in.) Clearance	1.63 m (5 ft. 4 in.)	1.65 m (5 ft. 5 in.)	1.63 m (5 ft. 4 in.)	1.65 m (5 ft. 5 in.)	1.63 m (5 ft. 4 in.)	1.65 m (5 ft. 5 in.)
K Maximum Digging Depth	99 mm (3.9 in.)	108 mm (4.3 in.)	99 mm (3.9 in.)	108 mm (4.3 in.)	99 mm (3.9 in.)	108 mm (4.3 in.)
L Maximum Rollback at Ground Level	40.5 deg.	40.5 deg.	40.5 deg.	40.5 deg.	40.5 deg.	40.5 deg.
M Maximum Rollback, Boom Fully Raised	55.0 deg.	55.0 deg.	55.0 deg.	55.0 deg.	55.0 deg.	55.0 deg.
N Maximum Bucket Dump Angle, Fully Raised	50.0 deg.	50.0 deg.	50.0 deg.	50.0 deg.	50.0 deg.	50.0 deg.
Loader Clearance Circle, Bucket Carry Position	13.05 m (42 ft. 10 in.)	13.21 m (43 ft. 4 in.)	13.05 m (42 ft. 10 in.)	13.21 m (43 ft. 4 in.)	13.05 m (42 ft. 10 in.)	13.21 m (43 ft. 4 in.)
Specifications With Bucket With Bolt-On Edge						
Capacity, Heaped	3.10 m ³ (4.00 cu. yd.)	3.20 m ³ (4.25 cu. yd.)	3.10 m ³ (4.00 cu. yd.)	3.20 m ³ (4.25 cu. yd.)	3.10 m ³ (4.00 cu. yd.)	3.20 m ³ (4.25 cu. yd.)
Capacity, Struck	2.65 m ³ (3.47 cu. yd.)	2.80 m ³ (3.67 cu. yd.)	2.65 m ³ (3.47 cu. yd.)	2.80 m ³ (3.67 cu. yd.)	2.65 m ³ (3.47 cu. yd.)	2.80 m ³ (3.67 cu. yd.)
Bucket Weight With Bolt-On Cutting Edge	1466 kg (3,232 lb.)	1736 kg (3,827 lb.)	1466 kg (3,232 lb.)	1736 kg (3,827 lb.)	1466 kg (3,232 lb.)	1736 kg (3,827 lb.)
Bucket Width	2.94 m (9 ft. 8 in.)	3.04 m (10 ft. 0 in.)	2.94 m (9 ft. 8 in.)	3.04 m (10 ft. 0 in.)	2.94 m (9 ft. 8 in.)	3.04 m (10 ft. 0 in.)
Breakout Force	14 462 kg (31,883 lb.)	13 502 kg (29,767 lb.)	14 462 kg (31,883 lb.)	13 502 kg (29,767 lb.)	14 462 kg (31,883 lb.)	13 502 kg (29,767 lb.)
Tipping Load, Straight, No Tire Deflection	14 194 kg (31,292 lb.)	13 742 kg (30,296 lb.)	14 251 kg (31,418 lb.)	13 798 kg (30,419 lb.)	15 430 kg (34,017 lb.)	14 963 kg (32,987 lb.)
Tipping Load, Straight, With Tire Deflection	13 356 kg (29,445 lb.)	12 924 kg (28,493 lb.)	13 407 kg (29,557 lb.)	12 975 kg (28,605 lb.)	14 523 kg (32,018 lb.)	14 079 kg (31,039 lb.)
Tipping Load, 40-deg. Full Turn, No Tire Deflection	12 278 kg (27,068 lb.)	11 849 kg (26,122 lb.)	12 328 kg (27,178 lb.)	11 898 kg (26,230 lb.)	13 347 kg (29,425 lb.)	12 906 kg (28,453 lb.)
Tipping Load, 40-deg. Full Turn, With Tire Deflection	11 220 kg (24,736 lb.)	10 818 kg (23,850 lb.)	11 262 kg (24,828 lb.)	10 860 kg (23,942 lb.)	12 102 kg (26,680 lb.)	11 691 kg (25,774 lb.)

644 G-TIER

While general information, pictures, and descriptions are provided, some illustrations and text may include product options and accessories NOT AVAILABLE in all regions, and in some countries products and accessories may require modifications or additions to ensure compliance with the local regulations of those countries.

Dimensions and Specifications With Pin-On Bucket With Bolt-On Edge (continued)	644 G Z-BAR TIER 2		644 G Z-BAR TIER 3		644 G Z-BAR FINAL TIER (FT4)	
Specifications With Bucket With Bolt-On Edge (continued)	3.10-m ³ (4.00 cu. yd.)	3.20-m ³ (4.25 cu. yd.)	3.10-m ³ (4.00 cu. yd.)	3.20-m ³ (4.25 cu. yd.)	3.10-m ³ (4.00 cu. yd.)	3.20-m ³ (4.25 cu. yd.)
Rated Operating Load, 50% Full-Turn Tipping Load, No Tire Deflection (conforms to ISO 14397-1)*	6139 kg (13,534 lb.)	5924.5 kg (13,061 lb.)	6164 kg (13,589 lb.)	5949 kg (13,115 lb.)	6673.5 kg (14,712 lb.)	6453 kg (14,226 lb.)
Rated Operating Load, 50% Full-Turn Tipping Load, With Tire Deflection (conforms to ISO 14397-1)*	5610 kg (12,368 lb.)	5409 kg (11,925 lb.)	5631 kg (12,414 lb.)	5430 kg (11,971 lb.)	6051 kg (13,340 lb.)	5845.5 kg (12,887 lb.)
Operating Weight	17 009 kg (37,498 lb.)	17 279 kg (38,093 lb.)	17 044 kg (37,575 lb.)	17 314 kg (38,170 lb.)	17 934 kg (39,537 lb.)	18 205 kg (40,135 lb.)

Loader operating information is based on machine with identified linkage and standard equipment, John Deere PowerTech 6068H/PowerTech Plus 6068H/PowerTech PVS 6068H engine, ROPS cab, rear cast bumper/counterweight, transmission side-frame guards, bottom guards, standard tires, full fuel tank, and 79-kg (175 lb.) operator. This information is affected by changes in tires, ballast, and different attachments, and assumes no tire deflection per the standard ISO 14397-1 section 5.

*Rated operating capacity based on Deere attachments only.

Dimensions and Specifications With Hi-Vis Coupler and Hook-On Bucket With Bolt-On Edge

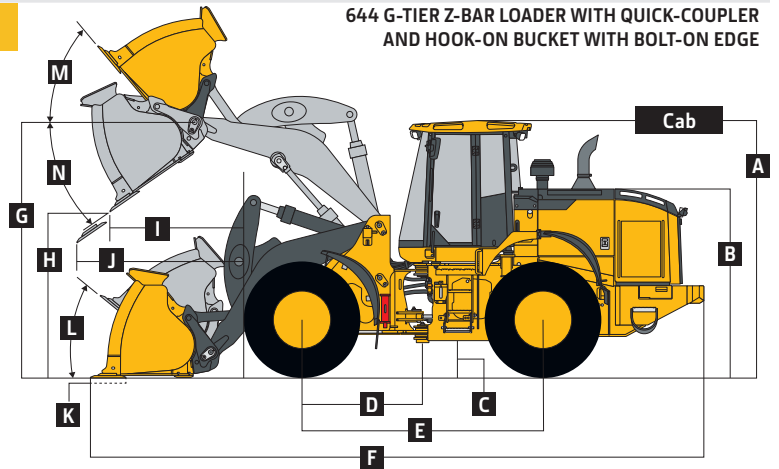

	644 G Z-Bar Tier 2	644 G Z-Bar Tier 3	644 G Z-Bar FT4
Dimensions With Bucket With Bolt-On Edge (illustration above right)	3.10-m ³ (4.00 cu. yd.) general-purpose		
A Height to Top of Cab	3.46 m (11 ft. 4 in.)	3.46 m (11 ft. 4 in.)	3.46 m (11 ft. 4 in.)
B Hood Height	2.63 m (8 ft. 8 in.)	2.63 m (8 ft. 8 in.)	2.63 m (8 ft. 8 in.)
C Ground Clearance	422 mm (16.6 in.)	422 mm (16.6 in.)	422 mm (16.6 in.)
D Length From Centerline to Front Axle	1.60 m (5 ft. 3 in.)	1.60 m (5 ft. 3 in.)	1.60 m (5 ft. 3 in.)
E Wheelbase	3.26 m (10 ft. 8 in.)	3.26 m (10 ft. 8 in.)	3.26 m (10 ft. 8 in.)
F Overall Length, Bucket on Ground	8.29 m (27 ft. 2 in.)	8.29 m (27 ft. 2 in.)	8.29 m (27 ft. 2 in.)
G Height to Hinge Pin, Fully Raised	4.13 m (13 ft. 7 in.)	4.13 m (13 ft. 7 in.)	4.13 m (13 ft. 7 in.)
H Dump Clearance, 45 deg., Full Height	2.83 m (9 ft. 3 in.)	2.83 m (9 ft. 3 in.)	2.83 m (9 ft. 3 in.)
I Reach, 45-deg. Dump, Full Height	1.13 m (3 ft. 8 in.)	1.13 m (3 ft. 8 in.)	1.13 m (3 ft. 8 in.)
J Reach, 45-deg. Dump, 2.13-m (7 ft. 0 in.) Clearance	1.67 m (5 ft. 6 in.)	1.67 m (5 ft. 6 in.)	1.67 m (5 ft. 6 in.)
K Maximum Digging Depth	129 mm (5 in.)	129 mm (5 in.)	129 mm (5 in.)
L Maximum Rollback at Ground Level	41 deg.	41 deg.	41 deg.
M Maximum Rollback, Boom Fully Raised	55 deg.	55 deg.	55 deg.
N Maximum Bucket Dump Angle, Fully Raised	50 deg.	50 deg.	50 deg.
Loader Clearance Circle, Bucket Carry Position	13.26 m (43 ft. 6 in.)	13.26 m (43 ft. 6 in.)	13.26 m (43 ft. 6 in.)
Specifications With Bucket With Bolt-On Edge	3.10-m ³ (4.00 cu. yd.) general-purpose		
Capacity, Heaped	3.10 m ³ (4.00 cu. yd.)	3.10 m ³ (4.00 cu. yd.)	3.10 m ³ (4.00 cu. yd.)
Capacity, Struck	2.50 m ³ (3.27 cu. yd.)	2.50 m ³ (3.27 cu. yd.)	2.50 m ³ (3.27 cu. yd.)
Bucket Weight With Bolt-On Cutting Edge	2223 kg (4,901 lb.)	2223 kg (4,901 lb.)	2223 kg (4,901 lb.)
Bucket Width	3.04 m (10 ft. 0 in.)	3.04 m (10 ft. 0 in.)	3.04 m (10 ft. 0 in.)
Breakout Force	12 285 kg (27,084 lb.)	12 285 kg (27,084 lb.)	12 285 kg (27,084 lb.)
Tipping Load, Straight, No Tire Deflection	12 461 kg (27,472 lb.)	12 514 kg (27,589 lb.)	13 611 kg (30,007 lb.)
Tipping Load, Straight, With Tire Deflection	11 718 kg (25,834 lb.)	11 766 kg (25,940 lb.)	12 813 kg (28,248 lb.)
Tipping Load, 40-deg. Full Turn, No Tire Deflection	10 680 kg (23,545 lb.)	10 726 kg (23,647 lb.)	11 674 kg (25,737 lb.)
Tipping Load, 40-deg. Full Turn, With Tire Deflection	9735 kg (21,462 lb.)	9774 kg (21,548 lb.)	10 566 kg (23,294 lb.)
Rated Operating Load, 50% Full-Turn Tipping Load, No Tire Deflection (conforms to ISO 14397-1)*	5340 kg (11,773 lb.)	5363 kg (11,823 lb.)	5837 kg (12,868 lb.)
Rated Operating Load, 50% Full-Turn Tipping Load, With Tire Deflection (conforms to ISO 14397-1)*	4867.5 kg (10,731 lb.)	4887 kg (10,774 lb.)	5283 kg (11,647 lb.)
Operating Weight	17 766 kg (39,167 lb.)	17 801 kg (39,244 lb.)	18 692 kg (41,209 lb.)

Loader operating information is based on machine with identified linkage and standard equipment, John Deere PowerTech™ 6068H/PowerTech Plus 6068H/PowerTech PVS 6068H engine, ROPS cab, rear cast bumper/counterweight, transmission side-frame guards, bottom guards, standard tires, full fuel tank, and 79-kg (175 lb.) operator. This information is affected by changes in tires, ballast, and different attachments, and assumes no tire deflection per the standard ISO 14397-1 section 5.

*Rated operating capacity based on Deere attachments only.

While general information, pictures, and descriptions are provided, some illustrations and text may include product options and accessories NOT AVAILABLE in all regions, and in some countries products and accessories may require modifications or additions to ensure compliance with the local regulations of those countries.

644 G-TIER

Dimensions and Specifications With Hi-Vis Coupler and Construction Forks 644 G Z-BAR TIER 2 / TIER 3 / FT4

644 G-TIER Z-BAR LOADER WITH HI-VIS COUPLER AND HOOK-ON CONSTRUCTION FORKS

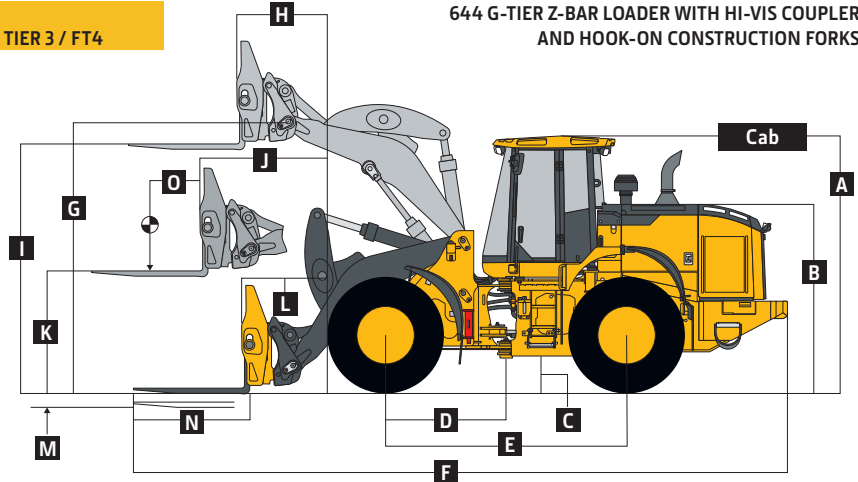

	644 G Z-Bar Tier 2		644 G Z-Bar Tier 3		644 G Z-Bar FT4	
Dimensions With Forks <i>(illustration above right)</i>	1.52-m (60 in.)	1.83-m (72 in.)	1.52-m (60 in.)	1.83-m (72 in.)	1.52-m (60 in.)	1.83-m (72 in.)
	<i>tine length</i>	<i>tine length</i>	<i>tine length</i>	<i>tine length</i>	<i>tine length</i>	<i>tine length</i>
A Height to Top of Cab	3.46 m (11 ft. 4 in.)	3.46 m (11 ft. 4 in.)	3.46 m (11 ft. 4 in.)	3.46 m (11 ft. 4 in.)	3.46 m (11 ft. 4 in.)	3.46 m (11 ft. 4 in.)
B Hood Height	2.63 m (8 ft. 8 in.)	2.63 m (8 ft. 8 in.)	2.63 m (8 ft. 8 in.)	2.63 m (8 ft. 8 in.)	2.63 m (8 ft. 8 in.)	2.63 m (8 ft. 8 in.)
C Ground Clearance	422 mm (16.6 in.)	422 mm (16.6 in.)	422 mm (16.6 in.)	422 mm (16.6 in.)	422 mm (16.6 in.)	422 mm (16.6 in.)
D Length From Centerline to Front Axle	1.60 m (5 ft. 3 in.)	1.60 m (5 ft. 3 in.)	1.60 m (5 ft. 3 in.)	1.60 m (5 ft. 3 in.)	1.60 m (5 ft. 3 in.)	1.60 m (5 ft. 3 in.)
E Wheelbase	3.26 m (10 ft. 8 in.)	3.26 m (10 ft. 8 in.)	3.26 m (10 ft. 8 in.)	3.26 m (10 ft. 8 in.)	3.26 m (10 ft. 8 in.)	3.26 m (10 ft. 8 in.)
F Overall Length, Forks on Ground	8.97 m (29 ft. 5 in.)	9.27 m (30 ft. 5 in.)	8.97 m (29 ft. 5 in.)	9.27 m (30 ft. 5 in.)	8.97 m (29 ft. 5 in.)	9.27 m (30 ft. 5 in.)
G Height to Hinge Pin, Fully Raised	4.13 m (13 ft. 7 in.)	4.13 m (13 ft. 7 in.)	4.13 m (13 ft. 7 in.)	4.13 m (13 ft. 7 in.)	4.13 m (13 ft. 7 in.)	4.13 m (13 ft. 7 in.)
H Reach, Fully Raised	875 mm (34 in.)	875 mm (34 in.)	875 mm (34 in.)	875 mm (34 in.)	875 mm (34 in.)	875 mm (34 in.)
I Fork Height, Fully Raised	3.80 m (12 ft. 6 in.)	3.80 m (12 ft. 6 in.)	3.80 m (12 ft. 6 in.)	3.80 m (12 ft. 6 in.)	3.80 m (12 ft. 6 in.)	3.80 m (12 ft. 6 in.)
J Maximum Reach, Fork Level	1.77 m (5 ft. 10 in.)	1.77 m (5 ft. 10 in.)	1.77 m (5 ft. 10 in.)	1.77 m (5 ft. 10 in.)	1.77 m (5 ft. 10 in.)	1.77 m (5 ft. 10 in.)
K Fork Height, Maximum Reach	1.71 m (5 ft. 7 in.)	1.71 m (5 ft. 7 in.)	1.71 m (5 ft. 7 in.)	1.71 m (5 ft. 7 in.)	1.71 m (5 ft. 7 in.)	1.71 m (5 ft. 7 in.)
L Reach, Ground Level	1.15 m (3 ft. 9 in.)	1.15 m (3 ft. 9 in.)	1.15 m (3 ft. 9 in.)	1.15 m (3 ft. 9 in.)	1.15 m (3 ft. 9 in.)	1.15 m (3 ft. 9 in.)
M Depth Below Ground	155 mm (6 in.)	155 mm (6 in.)	155 mm (6 in.)	155 mm (6 in.)	155 mm (6 in.)	155 mm (6 in.)
N Tine Length	1.52 m (60 in.)	1.83 m (72 in.)	1.52 m (60 in.)	1.83 m (72 in.)	1.52 m (60 in.)	1.83 m (72 in.)
O Load Position, 50% Tine Length	0.76 m (30 in.)	0.91 m (36 in.)	0.76 m (30 in.)	0.91 m (36 in.)	0.76 m (30 in.)	0.91 m (36 in.)

Specifications With Forks

Tipping Load, Straight, No Tire Deflection	8868 kg (19,551 lb.)	8411 kg (18,543 lb.)	8904 kg (19,630 lb.)	8446 kg (18,620 lb.)	9662 kg (21,301 lb.)	9170 kg (20,216 lb.)
Tipping Load, Straight, With Tire Deflection	8616 kg (18,995 lb.)	8175 kg (18,023 lb.)	8652 kg (19,074 lb.)	8211 kg (18,102 lb.)	9405 kg (20,734 lb.)	8934 kg (19,696 lb.)
Tipping Load, 40-deg. Full Turn, No Tire Deflection	7638 kg (16,839 lb.)	7235 kg (15,950 lb.)	7670 kg (16,909 lb.)	7265 kg (16,017 lb.)	8325 kg (18,353 lb.)	7891 kg (17,397 lb.)
Tipping Load, 40-deg. Full Turn, With Tire Deflection	7302 kg (16,098 lb.)	6921 kg (15,258 lb.)	7332 kg (16,164 lb.)	6948 kg (15,318 lb.)	7941 kg (17,507 lb.)	7536 kg (16,614 lb.)
Rated Operating Load, 50% Full-Turn Tipping Load, With Tire Deflection (conforms to ISO 14397-1 and SAE J1197)*	3651 kg (8,049 lb.)	3461 kg (7,630 lb.)	3666 kg (8,082 lb.)	3474 kg (7,659 lb.)	3970.5 kg (8,753 lb.)	3768 kg (8,307 lb.)
Rated Operating Load, Rough Terrain, 60% Full-Turn Tipping Load, With Tire Deflection (conforms to EN474-3)*	4381 kg (9,658 lb.)	4153 kg (9,156 lb.)	4399 kg (9,698 lb.)	4169 kg (9,191 lb.)	4765 kg (10,505 lb.)	4522 kg (9,969 lb.)
Rated Operating Load, Firm and Level Ground, 80% Full-Turn Tipping Load, With Tire Deflection (conforms to EN474-3)*	5842 kg (12,879 lb.)	5537 kg (12,207 lb.)	5866 kg (12,932 lb.)	5558 kg (12,253 lb.)	6353 kg (14,006 lb.)	6029 kg (13,292 lb.)
Operating Weight	17 231 kg (37,988 lb.)	17 291 kg (38,120 lb.)	17 266 kg (38,065 lb.)	17 326 kg (38,197 lb.)	18 157 kg (40,029 lb.)	18 217 kg (40,162 lb.)

Loader operating information is based on machine with identified linkage and standard equipment, John Deere PowerTech 6068H/PowerTech Plus 6068H/PowerTech PVS 6068H engine, ROPS cab, rear cast bumper/counterweight, transmission side-frame guards, bottom guards, standard tires, full fuel tank, and 79-kg (175 lb.) operator. This information is affected by changes in tires, ballast, and different attachments, and assumes no tire deflection per the standard ISO 14397-1 section 5.

*Rated operating capacity based on Deere attachments only.

644 G Z-BAR TIER 2 Adjustments to Operating Weights and Tipping Loads With Buckets

Adjustments to operating weights, tipping loads, and tires are based on Z-Bar machine with pin-on 3.25-m³ (4.25 cu. yd.) high-performance bucket with bolt-on cutting edge, ROPS cab, rear cast bumper/counterweight, transmission side-frame guards, bottom guards, standard tires, full fuel tank, and 79-kg (175 lb.) operator*

Add (+) or deduct (-) kg (lb.) as indicated for loaders with 3-piece rims	Operating Weight	Tipping Load, Straight	Tipping Load, 40-deg. Full Turn	Tread Width	Width Over Tires	Vertical Height
Linglong 23.5-25 TL, E3/L3, 16PR Bias Tire	0 kg (0 lb.)	0 kg (0 lb.)	0 kg (0 lb.)	0 mm (0 in.)	0 mm (0 in.)	0 mm (0 in.)
TianLi 23.5 R25, 2 Star TUL300 (E3/L3), TL Radial Tire	+ 406 kg (+ 895 lb.)	+ 308 kg (+ 679 lb.)	+ 271 kg (+ 597 lb.)	0 mm (0 in.)	+ 20 mm (+ 0.8 in.)	+ 7 mm (+ 0.3 in.)
Maxam 23.5 R 25, 2 Star L-3 Radial Tire	+ 445 kg (+ 981 lb.)	+ 339 kg (+ 747 lb.)	+ 299 kg (+ 659 lb.)	0 mm (0 in.)	+ 92 mm (+ 3.6 in.)	- 43 mm (- 1.7 in.)
Maxam 23.5 R 25, 2 Star L-2 Radial Tire	+ 453 kg (+ 999 lb.)	+ 345 kg (+ 761 lb.)	+ 304 kg (+ 670 lb.)	0 mm (0 in.)	+ 93 mm (+ 3.7 in.)	- 43 mm (- 1.7 in.)

*May change based on vehicle configuration, weight, or tire-pressure adjustments.

644 G-TIER

While general information, pictures, and descriptions are provided, some illustrations and text may include product options and accessories NOT AVAILABLE in all regions, and in some countries products and accessories may require modifications or additions to ensure compliance with the local regulations of those countries.

644 G Z-BAR TIER 3 Adjustments to Operating Weights and Tipping Loads With Buckets

Adjustments to operating weights, tipping loads, and tires are based on Z-Bar machine with pin-on 3.25-m³ (4.25 cu. yd.) high-performance bucket with bolt-on cutting edge, ROPS cab, rear cast bumper/counterweight, transmission side-frame guards, bottom guards, standard tires, full fuel tank, and 79-kg (175 lb.) operator*

Add (+) or deduct (-) kg (lb.) as indicated	Operating Weight	Tipping Load, Straight	Tipping Load, 40-deg. Full Turn	Tread Width	Width Over Tires	Vertical Height
for loaders with 3-piece rims						
Linglong 23.5-25 TL, E3/L3, 16PR Bias Tire	0 kg (0 lb.)	0 kg (0 lb.)	0 kg (0 lb.)	0 mm (0 in.)	0 mm (0 in.)	0 mm (0 in.)
TianLi 23.5 R25, 2 Star TUL300 (E3/L3), TL Radial Tire	+ 406 kg (+ 895 lb.)	+ 309 kg (+ 681 lb.)	+ 272 kg (+ 600 lb.)	0 mm (0 in.)	+ 20 mm (+ 0.8 in.)	+ 7 mm (+ 0.3 in.)
Maxam 23.5 R 25, 2 Star L-3 Radial Tire	+ 445 kg (+ 981 lb.)	+ 339 kg (+ 747 lb.)	+ 299 kg (+ 659 lb.)	0 mm (0 in.)	+ 92 mm (+ 3.6 in.)	- 43 mm (- 1.7 in.)
Maxam 23.5 R 25, 2 Star L-2 Radial Tire	+ 453 kg (+ 999 lb.)	+ 345 kg (+ 761 lb.)	+ 304 kg (+ 670 lb.)	0 mm (0 in.)	+ 93 mm (+ 3.7 in.)	- 43 mm (- 1.7 in.)

*May change based on vehicle configuration, weight, or tire-pressure adjustments.

644 G Z-BAR FT4 Adjustments to Operating Weights and Tipping Loads With Buckets

Adjustments to operating weights, tipping loads, and tires are based on Z-Bar machine with pin-on 3.25-m³ (4.25 cu. yd.) high-performance bucket with bolt-on cutting edge, ROPS cab, rear cast bumper/counterweight, transmission side-frame guards, bottom guards, standard tires, full fuel tank, and 79-kg (175 lb.) operator*

Add (+) or deduct (-) kg (lb.) as indicated	Operating Weight	Tipping Load, Straight	Tipping Load, 40-deg. Full Turn	Tread Width	Width Over Tires	Vertical Height
for loaders with 3-piece rims						
Linglong 23.5-25 TL, E3/L3, 16PR Bias Tire	N/A	N/A	N/A	N/A	N/A	N/A
TianLi 23.5 R25, 2 Star TUL300 (E3/L3), TL Radial Tire	0 kg (0 lb.)	0 kg (0 lb.)	0 kg (0 lb.)	0 mm (0 in.)	0 mm (0 in.)	0 mm (0 in.)
Maxam 23.5 R 25, 2 Star L-3 Radial Tire	+ 40 kg (+ 88 lb.)	+ 30 kg (+ 66 lb.)	+ 27 kg (+ 60 lb.)	0 mm (0 in.)	+ 17 mm (+ 0.7 in.)	- 28 mm (- 1.1 in.)
Maxam 23.5 R 25, 2 Star L-2 Radial Tire	+ 48 kg (+ 106 lb.)	+ 36 kg (+ 79 lb.)	+ 32 kg (+ 71 lb.)	0 mm (0 in.)	+ 18 mm (+ 0.7 in.)	- 28 mm (- 1.1 in.)

*May change based on vehicle configuration, weight, or tire-pressure adjustments.

Bucket Selection Guides*

Key: General-Purpose (GP)

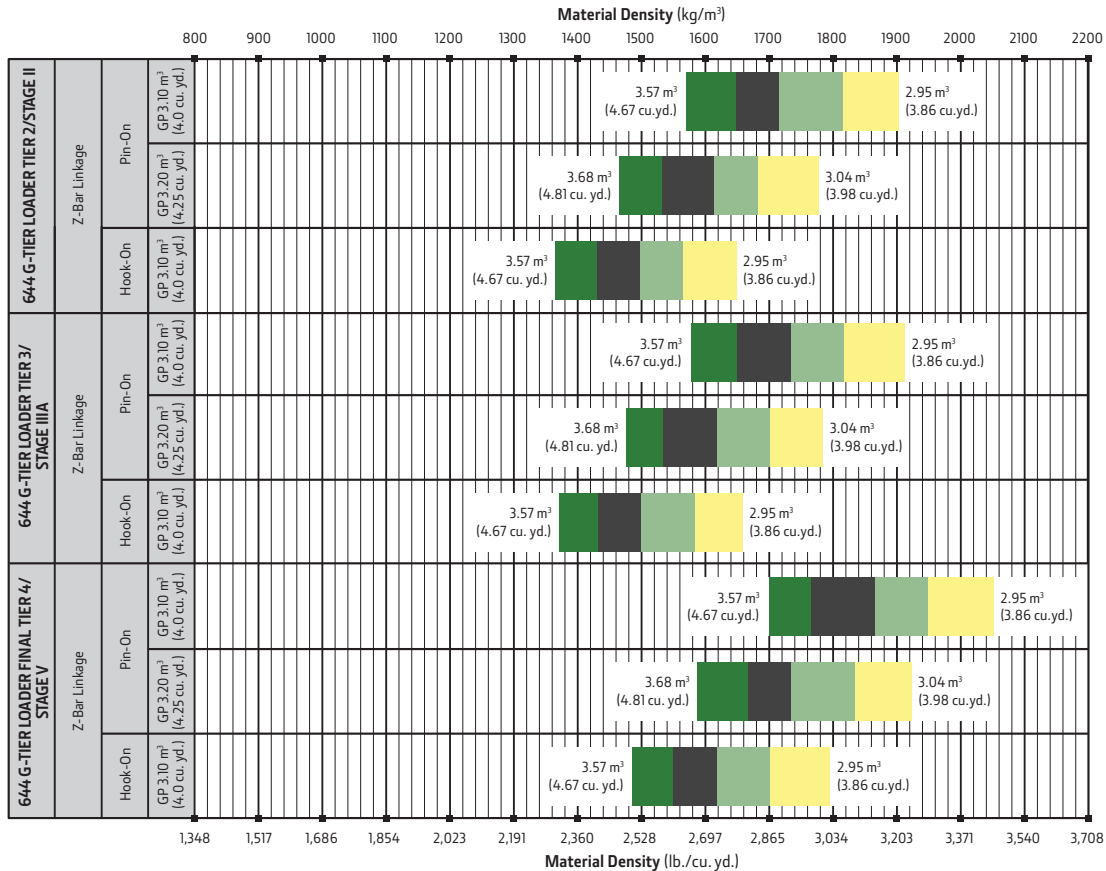

LOOSE MATERIALS	kg/m ³	lb./cu. yd.	LOOSE MATERIALS	kg/m ³	lb./cu. yd.
Chips, pulpwood	288	486	Limestone, coarse, sized	1570	2,646
Cinders (coal, ashes, clinkers)	673	1,134	Limestone, mixed sizes	1682	2,835
Clay and gravel, dry	1602	2,700	Limestone, pulverized or crushed	1362	2,295
Clay, compact, solid	1746	2,943	Sand, damp	2083	3,510
Clay, dry in lump loose	1009	1,701	Sand, dry	1762	2,970
Clay, excavated in water	1282	2,160	Sand, voids, full of water	2083	3,510
Coal, anthracite, broken, loose	865	1,458	Sandstone, quarried	1314	2,214
Coal, bituminous, moderately wet	801	1,350	Shale, broken crushed	1362	2,295
Earth, common loam, dry	1218	2,052	Slag, furnace granulated	1955	3,294
Earth, mud, packed	1843	3,105	Stone or gravel, 37.5 to 87.5-mm (1.5 to 3.5") size	1442	2,430
Granite, broken	1538	2,592	Stone or gravel, 18.75-mm (0.75") size	1602	2,700
Gypsum	2275	3,834			

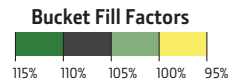

Additional equipment

Key: ● Standard ▲ Optional or special
See your John Deere dealer for further information.

644 G Engine

- Wet-sleeve cylinder liners
- Programmable auto-idle and auto shutdown
- Starter excessive-cranking protection
- Automatic engine cool-down timer
- Automatic derating for exceeded system temperatures
- Serpentine drive belt for automatic tensioner
- Electrical fuel-priming pump
- Dual-stage fuel filter and water separator
- 500-hour vertical spin-on oil filter
- Automatic glow plugs for cold start
- ▲ Engine-block heater (recommended for cold starts below -23 deg. C [-10 deg. F])
- ▲ Centrifugal engine air pre-cleaner

Powertrain

- Clutch cutoff with 3 operator settings: Level ground, small slope, or steep slope
- Clutch calibration engaged from monitor
- 2,000-hour vertical spin-on transmission filter
- Transmission fill tube and sight gauge
- Transmission diagnostic ports
- 4-speed transmission with non-lockup torque converter
- ▲ Front locking differential
- Brake retractors and adjusters

Cooling System

- Isolated from engine compartment
- Engine radiator
- Engine oil cooler
- Hydraulic oil cooler (oil to air)
- Transmission oil cooler (oil to air)
- Charge air cooler (air to air)
- Fuel cooler
- Coolant recovery tank
- Antifreeze, -47 deg. C [-52 deg. F]
- Cool-on-demand, hydraulically driven fan
- Enclosed fan safety guard
- ▲ Automatic reversing fan drive

Hydraulics

- Pilot hydraulic controls
- Automatic return-to-dig bucket positioner
- In-cab adjustable automatic boom-height kickout/return to carry
- Reservoir with sight gauge and fill strainer
- Hydraulic diagnostic ports
- 4,000-hour in-tank filter
- 2 function — joystick with F-N-R
- ▲ 2 function — 2-lever fingertip controls and steering column F-N-R

644 G Hydraulics (continued)

- ▲ 3 function — joystick with F-N-R and 3rd-function auxiliary lever
- ▲ 3 function — 3-lever fingertip controls and steering column F-N-R
- ▲ Ride control, automatic with monitor-adjustable speed settings
- ▲ Hydraulic control system for quick-coupler locking pins
- ▲ Hydra™ XR cold-temperature hydraulic fluid recommended below -25 deg. C [-13 deg. F]

Steering Systems

- Conventional steering wheel with spinner knob
- ▲ Secondary steering

Electrical

- Solid-state electrical power-distribution system
- Lockable master electrical-disconnect switch
- Battery-terminal safety covers
- By-pass start safety cover at starter
- Pre-wired for beacon/strobe light
- ▲ Rotary beacon
- Lights: Halogen driving lights (2) / Front (2) and rear cab (2) / Halogen front turn signals and flashers / LED stop- and taillights
- ▲ Halogen rear grille work lights (2)
- Horn, electric
- Reverse warning alarm
- Multifunction/multi-language 127-mm (5 in.) LCD color monitor includes: Digital instruments — Analog display (hydraulic oil temperature, engine coolant temperature, transmission oil temperature, and engine oil pressure) / Digital display (engine rpm, transmission gear/direction indicator, hour meter, fuel level, diesel exhaust fluid (DEF) level, speedometer, odometer, and average fuel consumption)
- Indicator lights: Standard and selected options / Amber caution and red stop
- Operator-warning messages
- Built-in diagnostics: Diagnostic-code details / Sensor values / Calibrations / Individual circuit tester
- Radio ready
- ▲ AM/FM radio
- 24- to 12-volt, 15-amp converter and cab power port

Operator's Station

- Cab with air conditioning/heater (ROPS/FOPS Level 2, isolation mounted)
- Keyless start with multiple security modes
- Sealed-switch module with function indicators
- Seat with headrest extension, fabric cover, and adjustable mechanical suspension

644 G Operator's Station (continued)

- ▲ Seat with headrest extension, fabric cover, and adjustable air suspension
- High-visibility, bright-orange seat belt, 76 mm (3 in.), with retractor
- Cup holder
- Coat hook
- Dome and reading light
- Rubber floor mat
- Tilt steering column
- Operator's manual storage compartment
- Outside (2) and inside (1) rearview mirrors
- ▲ Heated outside mirrors with convex lens
- Left-side operator-station access
- Slip-resistant steps and ergonomic handholds
- Pull-down front sun visor
- Front and rear intermittent windshield wipers and washers
- Rearview camera
- ▲ Fire extinguisher bracket

Loader Linkage

- Z-Bar loader linkage

Buckets and Attachments

- ▲ Full line of Deere pin-on buckets, coupler buckets, and forks
- ▲ Hi-Vis hydraulic coupler that accepts Euro-pattern attachments (ISO)

Overall Vehicle

- JDLINK™ wireless communication system (available in specific countries; see your dealer for details)
- Front and rear tie-downs
- Rear counterweight with hitch and locking pin
- Articulation locking bar
- Loader boom service locking bar
- 40-deg. steering articulation to each side with rubber-cushion stops on frame
- Vandal protection with lockable engine enclosures, counterweight compartments, and filler access for radiator/fuel/DEF/hydraulic transmission
- Left-side service steps and handholds
- ▲ Right-side service steps and handrails
- Fuel-tank fill strainer
- Ground-level fuel and DEF fill
- Same-side ground-level daily servicing
- 23.5R25 radial tires on 3-piece rims
- ▲ 23.5-25 bias tires on 3-piece rims
- Fenders, front narrow
- ▲ Fenders, front and rear full width
- ▲ Transmission side-frame and bottom guards
- ▲ Lift eyes
- ▲ License-plate bracket and light

While general information, pictures, and descriptions are provided, some illustrations and text may include product options and accessories NOT AVAILABLE in all regions, and in some countries products and accessories may require modifications or additions to ensure compliance with the local regulations of those countries.

Net engine power is with standard equipment including air cleaner, exhaust system, alternator, and cooling fan at test conditions per ISO 9249. No derating is required up to 3050-m (10,000 ft.) altitude. Specifications and design subject to change without notice. Specifications with the exception of bucket capacity are in accordance with all applicable ISO standards. Except where otherwise noted, these specifications are based on a unit with applicable linkage and standard equipment, ROPS cab, rear cast bumper/counterweight, transmission side-frame guards, bottom guards, standard tires, full fuel tank, and 79-kg (175 lb.) operator.



MW644GAB (22-07)



JOHN DEERE