

KT559

Telehandlers > 4t



KRAMER
on the safe side



The top model KT559 has a lift capacity of 5.5 tonnes and a stacking height of 8.75 metres. The 156 hp Deutz engine with a torque of 609 Nm combined with a max. bucket volume of up to 4 m³ allows for maximum handling capacity for applications in professional agriculture. The sensitive load sensing gear pump conveys up to 187 l/min, thus offering enough power for quick work cycles. Trailer loads of up to 20 tonnes are also no problem for this telehandler.

- Wheelbase: The long wheel base provides a high level of driving comfort, even on long journeys
- Middle axis synchronisation: Convenient switch-over of the three steering modes using electronic synchronisation of the steering axles when steering over the zero point
- Solid axles: Permanent 4-wheel drive combined with 100% lock differential in the front axle - traction in the most difficult conditions
- Level adjustment: Movement of the revolving superstructure using a touch button from the cabin for particularly demanding work applications
- Lift capacity: 5.5 tonne payload and a stacking height of 8.75 metres

KT559 Technical specifications

Operating data

Payload bei max. Reichweite	2,200 kg
Max. payload (LC 500mm)	5,500 kg
Max. stack height	8,750 mm
Payload at max. stack height	1,300 kg
Stack height at max. payload	6,400 mm
Reach at max. payload	2,400 mm
Max. reach	4,790 mm
Turning radius over tyres	4,415 mm
Operating weight (max.)	11,500 kg
Bucket capacity	1.2 m ³

Engine / Motor

Engine / Motor manufacturer	Deutz
Type / Model	TCD 4.1 / L4
Engine performance	115 kW
Emission standards stage	V
Exhaust aftertreatment system	DOC+DPF+SCR

Power transmission

Traction drive	ecospeedPRO
Travel speed (Serie)	40 km/h
Driving speed (option)	20 km/h
Travel speed (Option)	30 km/h
Differential lock	100% in the front axle
Standard tires	460/70-24

Operating hydraulics

Duty pump	Load-Sensing axial piston pump
Max. pump discharge capacity	187 l/min
Max. pump pressure	260 bar

Kinematics

Total swing angle of tool carrier	152 °
-----------------------------------	-------

Filling capacities

Fuel tank	180 l
DEF tank	12 l
Hydraulic oil tank	100 l

Sound emission

Measured value	105 dB(A)
Guaranteed value	106 dB(A)
Noise level at the driver's ear	78 dB(A)

Vibrations

Total vibrations value of the upper body extremities	< 2,5 m/s ²
Highest effective value of weighted acceleration for the body	< 0,5 m/s ²

KT559 Dimensions

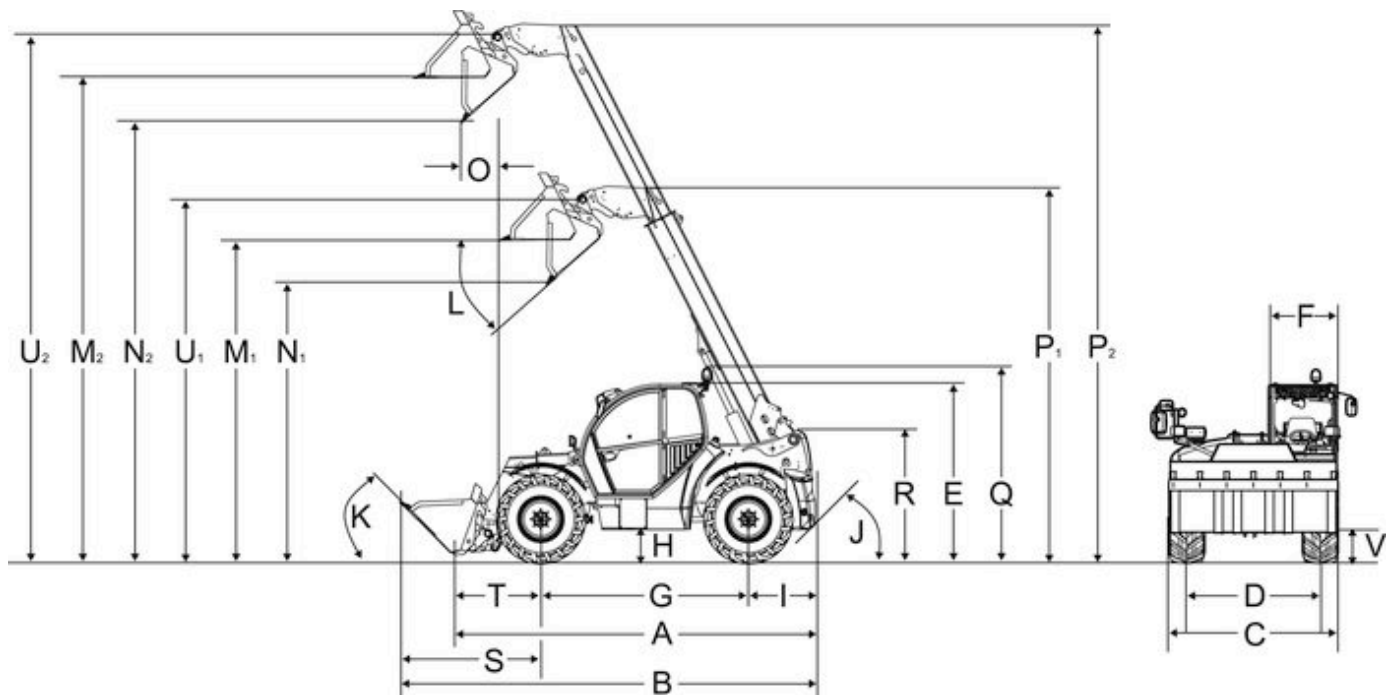

A	Overall length	5,890 mm
B	Overall length with bucket (max.)	6,690 mm
C	Overall width without attachment	2,500 mm
D1	Track width front	1,995 mm
D2	Track width rear	2,065 mm
E	Total height	2,570 mm
F	Cabin width	990 mm
G	Wheelbase center	3,150 mm
H	Ground clearance under axle and gearbox	412 mm
I	Distance center of rear wheel to rear	1,140 mm
J	Rear actuation angle	32 °
K	Tipping angle	45 °
L	Tip-out angle	41 °
M1	Overhead loading height - retracted	5,545 mm
M2	Overhead loading height - extended	8,498 mm
N1	Dumping height - retracted	5,015 mm
N2	Dumping height - extended	7,997 mm
O	Dump reach - extended	63 mm
P1	Length Tele Auszugslänge - eingefahren	6,277 mm
P2	Length Tele Auszugslänge - ausgefahren	9,243 mm
Q	Total height with rotating beacon	2,710 mm
R	Total height of the telescopic arm bearing in the frame	1,935 mm
S	Distance from the front wheel center to the front edge of the bucket (max.)	2,400 mm
T	Distance from the center of the bearing of the front wheel to the quick-change frame	1,310 mm
U1	Bucket pivot point - retracted	6,166 mm
U2	Bucket pivot point - extended	9,083 mm
V	Transport position with attachment	250 mm
-	Turning radius at the outer edge of the wheels	4,415 mm
-	Entry height, cabin floor	975 mm
-	Turning radius at the outer edge of the bucket	5,735 mm