

KT557

Telehandlers > 4t



KRAMER
on the safe side



The sturdy telehandler KT557 is designed for extremely demanding tasks. Trailer loads of up to 20 tonnes are no problem. The 156 hp Deutz engine (exhaust emission level V) combined with the standard ecospeedPRO drive system ensure excellent handling capacity. Partly-automated work cycles using the Smart Handling system can significantly increase the mass movements per hour. The multifunctional load stabiliser allows for a gentle application for man and machine.

- Hydraulics: Load-sensing gear pump with a discharge volume of max. 187 l/min
- Power transmission: 100% connectable differential lock in the front axle
- Efficiency: The powerful Deutz TCD 4.1 engine and the ecospeedPRO transmission for standard 40 km/h and rpm reduction to 1,800 rpm make transport work easy
- High quality cab: all important functional displays are combined in the A-column and are colour-coded
- Lift capacity: 5.5 tonne payload and a stacking height of 7 metres

KT557 Technical specifications

Operating data

Payload bei max. Reichweite	2,000 kg
Max. payload (LC 500)	5,500 kg
Max. stack height	7,017 mm
Payload at max. stack height	4,000 kg
Stack height at max. payload	5,500 mm
Reach at max. payload	1,890 mm
Max. reach	3,900 mm
Turning radius over tyres	4,240 mm
Operating weight (max.)	10,500 kg
Bucket capacity	1.2 m ³

Engine / Motor

Engine / Motor manufacturer	Deutz
Type / Model	TCD 4.1 / L4
Engine performance	115 kW
Emission standards stage	V
Exhaust aftertreatment system	DOC+DPF+SCR

Power transmission

Traction drive	ecospeedPRO
Travel speed max.	40 km/h
Differential lock	100% connectable in the front axle
Standard tires	460/70-24

Operating hydraulics

Duty pump	Load-Sensing axial piston pump
Max. pump discharge capacity	187 l/min
Max. pump pressure	260 bar

Kinematics

Total swing angle of tool carrier	152 °
-----------------------------------	-------

Filling capacities

Fuel tank	180 l
DEF tank	13 l
Hydraulic oil tank	100 l

Sound emission

Measured value	105 dB(A)
Guaranteed value	106 dB(A)
Noise level at the driver's ear	77 dB(A)

Vibrations

Total vibrations value of the upper body extremities	< 2,5 m/s ²
Highest effective value of weighted acceleration for the body	< 0,5 m/s ²

KT557 Dimensions

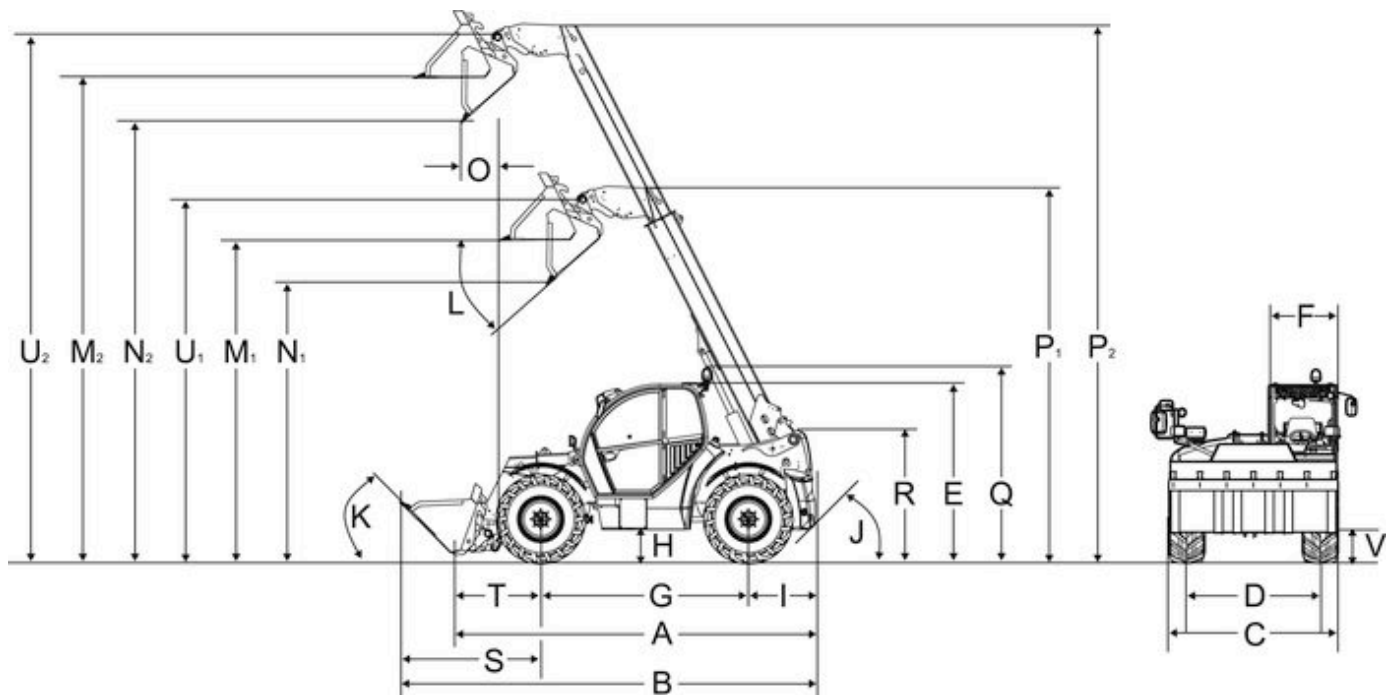

A	Overall length	4,985 mm
B	Overall length with bucket (max.)	6,160 mm
C	Overall width without attachment	2,500 mm
D1	Track width front	1,995 mm
D2	Track width rear	2,065 mm
E	Total height	2,570 mm
F	Cabin width	990 mm
G	Wheelbase center	2,950 mm
H	Ground clearance under axle and gearbox	418 mm
I	Distance center of rear wheel to rear	950 mm
J	Rear actuation angle	36.5 °
K	Tipping angle	45 °
L	Tip-out angle	41 °
M1	Overhead loading height - retracted	4,518 mm
M2	Overhead loading height - extended	6,835 mm
N1	Dumping height - retracted	3,865 mm
N2	Dumping height - extended	6,183 mm
O	Dump reach - extended	495 mm
P1	Length Tele Auszugslänge - eingefahren	5,287 mm
P2	Length Tele Auszugslänge - ausgefahren	7,604 mm
Q	Total height with rotating beacon	2,750 mm
R	Total height of the telescopic arm bearing in the frame	1,761 mm
S	Distance from the front wheel center to the front edge of the bucket (max.)	2,260 mm
T	Distance from the center of the bearing of the front wheel to the quick-change frame	753 mm
U1	Bucket pivot point - retracted	5,092 mm
U2	Bucket pivot point - extended	7,409 mm
V	Transport position with attachment	250 mm
-	Turning radius at the outer edge of the wheels	4,240 mm
-	Entry height, cabin floor	975 mm
-	Turning radius at the outer edge of the bucket	5,265 mm

All statements without guarantee. More detailed information on engine power can be found in the operator's manual and product brochures. Subject to alterations and errors excepted. Applicable also to illustrations.