

KT457

Telehandlers > 4t



KRAMER
on the safe side



4.5 tons payload and 7 meters stacking height

The Kramer KT457 has been specially designed for agriculture and is a versatile and powerful telehandler able to meet the highest demands. The maximum lift capacity of 4.5 tonnes and a stacking height of 7 metres ensure top performance of the loader unit. The vehicle is designed for high handling capacity as transverse forces are absorbed by the lateral support of the telescopic arm when pushing with a lowered boom. Trailer loads of up to 20 tonnes are no problem for the drive system.

- ecospeed drive system as standard: High pushing power combined with Smart Driving
- Safety: The operator assistance system, Smart Handling, with its three functional modes ensures that loads do not enter the overload range
- Optimised operation: The joystick attached to the driver's console prevents relative movements and allows for ergonomic operation
- Straight power train: Optimal power transmission with the help of straight-line maintenance-free cardan (universal) shafts
- Kramer quickhitch plate: Four support points allow for quick and efficient changing of the attachments

KT457 Technical specifications

Operating data

Payload bei max. Reichweite	1,500 kg
Max. payload (LSP 500 mm)	4,500 kg
Max. stack height	7,017 mm
Payload at max. stack height	3,300 kg
Stack height at max. payload	5,100 mm
Reach at max. payload	1,600 mm
Max. reach	3,790 mm
Turning radius over tyres	3,755 mm
Operating weight (max.)	9,000 kg
Bucket capacity	1.2 m ³

Engine / Motor

Engine / Motor manufacturer	Deutz
Type / Model	TCD 3.6 / L4
Engine performance	100 kW
Emission standards stage	V
Exhaust aftertreatment system	DOC + DPF + SCR

Power transmission

Traction drive	ecospeed
Travel speed (Serie)	40 km/h
Driving speed (option)	20 km/h
Travel speed (Option)	30 km/h
Differential lock	100% in the front axle
Standard tires	460/70-24

Operating hydraulics

Duty pump	Load-Sensing axial piston pump
Max. pump discharge capacity	140 l/min
Max. pump pressure	260 bar

Kinematics

Total swing angle of tool carrier	152 °
-----------------------------------	-------

Filling capacities

Fuel tank	180 l
DEF tank	13 l
Hydraulic oil tank	100 l

Sound emission

Measured value	105 dB(A)
Guaranteed value	106 dB(A)
Noise level at the driver's ear	78 dB(A)

Vibrations

Total vibrations value of the upper body extremities	< 2,5 m/s ²
Highest effective value of weighted acceleration for the body	< 0,5 m/s ²

KT457 Dimensions

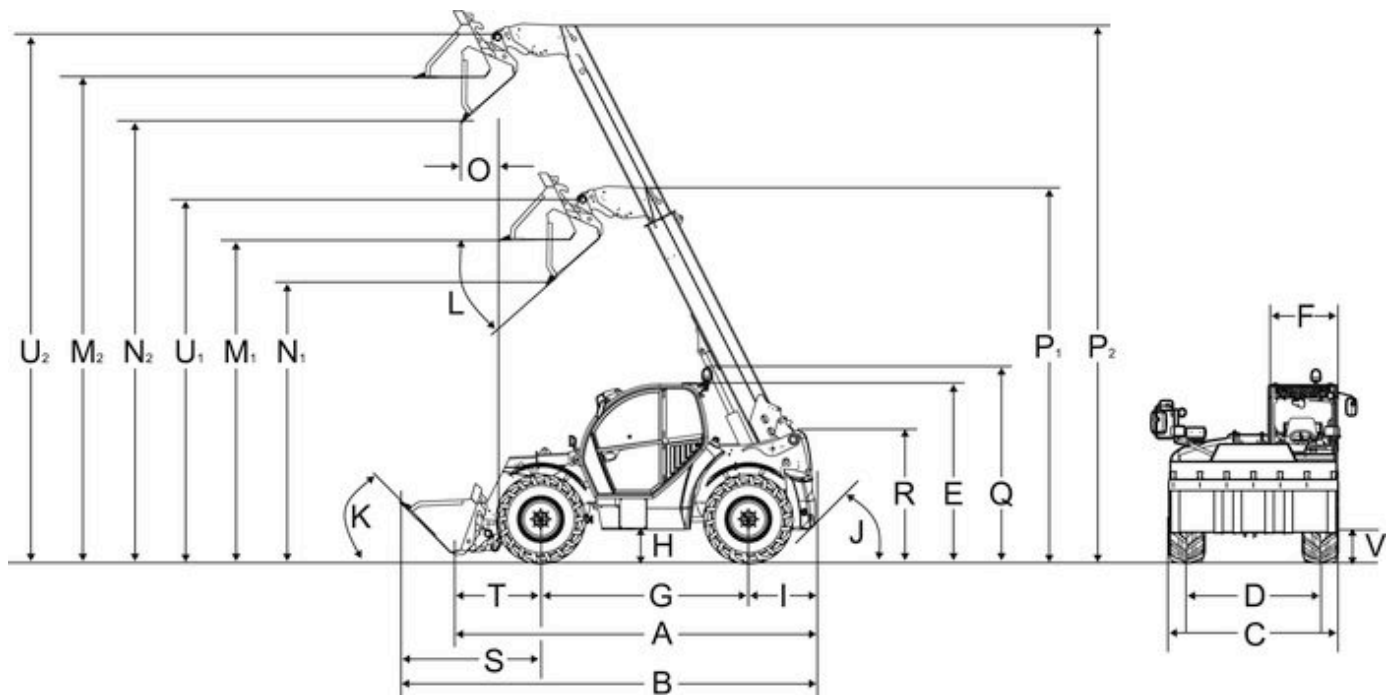

A	Overall length	4,985 mm
B	Overall length with bucket (max.)	6,160 mm
C	Overall width without attachment	2,500 mm
D1	Track width front	1,995 mm
D2	Track width rear	2,065 mm
E	Total height	2,570 mm
F	Cabin width	990 mm
G	Wheelbase center	2,950 mm
H	Ground clearance under axle and gearbox	418 mm
I	Distance center of rear wheel to rear	950 mm
J	Rear actuation angle	36.5 °
K	Tipping angle	45 °
L	Tip-out angle	41 °
M1	Overhead loading height - retracted	4,518 mm
M2	Overhead loading height - extended	6,835 mm
N1	Dumping height - retracted	3,865 mm
N2	Dumping height - extended	6,183 mm
O	Dump reach - extended	495 mm
P1	Length Tele Auszugslänge - eingefahren	5,287 mm
P2	Length Tele Auszugslänge - ausgefahren	7,604 mm
Q	Total height with rotating beacon	2,710 mm
R	Total height of the telescopic arm bearing in the frame	1,761 mm
S	Distance from the front wheel center to the front edge of the bucket (max.)	2,260 mm
T	Distance from the center of the bearing of the front wheel to the quick-change frame	753 mm
U1	Bucket pivot point - retracted	5,092 mm
U2	Bucket pivot point - extended	7,409 mm
V	Transport position with attachment	250 mm
-	Turning radius at the outer edge of the wheels	4,240 mm
-	Entry height, cabin floor	975 mm
-	Turning radius at the outer edge of the bucket	5,265 mm