

KT429

Telehandlers > 4t



KRAMER
on the safe side



9 m stacking height, a maximum payload of 4.2 t and 40 km/h final speed, as well as fast load processes are easy with the Kramer telehandler KT429 thanks to its sensitive load-sensing gear pump. Innovative details such as the 7 inch display, on which all vehicle data can be read, make the work easier. The new Jog Dial is operated intuitively and can, for example, set the work hydraulics.

- New operating concept: The intuitive and functional electronically piloted All-In-One joystick and the innovative Jog Dial control element enable easy operation of all functions.
- 7-inch display: All relevant vehicle data and settings are displayed on this display. The footage of the optional reversing camera is also integrated into the display.
- ecospeedPRO (optional): In typical work situations, e.g. handling work in the Y-cycle, there is a high demand for constant pushing and pulling forces at low travel speeds. The ecospeedPRO transmission exactly meets these requirements.
- The sensitive load-sensing hydraulic pump conveys 140 l/min, offering enough performance for quick load processes. For even more performance a hydraulic pump with 187 l/min is optionally available.
- Reduced noise development, low fuel consumption and reduced load on the individual elements become possible thanks to intelligent engine rpm reduction, in short Smart Driving.

KT429 Technical specifications

Operating data

Max. payload	4,200 kg
Max. stack height	8,750 mm
Payload at max. stack height	4,200 kg
Payload at max. reach	1,500 kg
Stack height at max. payload	8,750 mm
Max. reach	4,790 mm
Turning radius over tyres	4,415 mm
Operating weight	10,500 kg

Engine / Motor

Engine / Motor manufacturer	Deutz
Type / Model	TCD 3.6 / L4
Engine performance	100 kW
Torque	500
Displacement	3,621 cm ³
Emission standards stage	V
Exhaust aftertreatment system	DOC + DPF + SCR

Power transmission

Traction drive	ecospeed
Travel speed	30 km/h
Driving speed (option)	40 km/h
Differential lock	100% connectable in the front axle
Service brake	Multi-disc brake in the front and rear axle
Parking brake	Electro-hydraulic multi-disc brake with spring mechanism, automatic activation during engine stop
Standard tires	460/70R24 (AS tread)

Operating hydraulics

Duty pump	Load-sensing axial piston pump
Max. pump discharge capacity (Series)	140 l/min
Max. pump discharge capacity (Option)	187 l/min
Max. pump pressure	215 bar

Kinematics

Total swing angle of tool carrier	152 °
-----------------------------------	-------

Filling capacities

Fuel tank	180 l
DEF tank	12 l
Hydraulic oil tank	100 l

Sound emission

Measured value	104 dB(A)
Guaranteed value	106 dB(A)
Noise level at the driver's ear	76 dB(A)

Vibrations

Total vibrations value of the upper body extremities	< 2.5 m/s ² (<8.2 feet/s ²)
Highest effective value of weighted acceleration for the body	< 0.5 m/s ² / 1.28 m/s ² (1.64 feet/s ² / 4.19 feet/s ²)

KT429 Dimensions

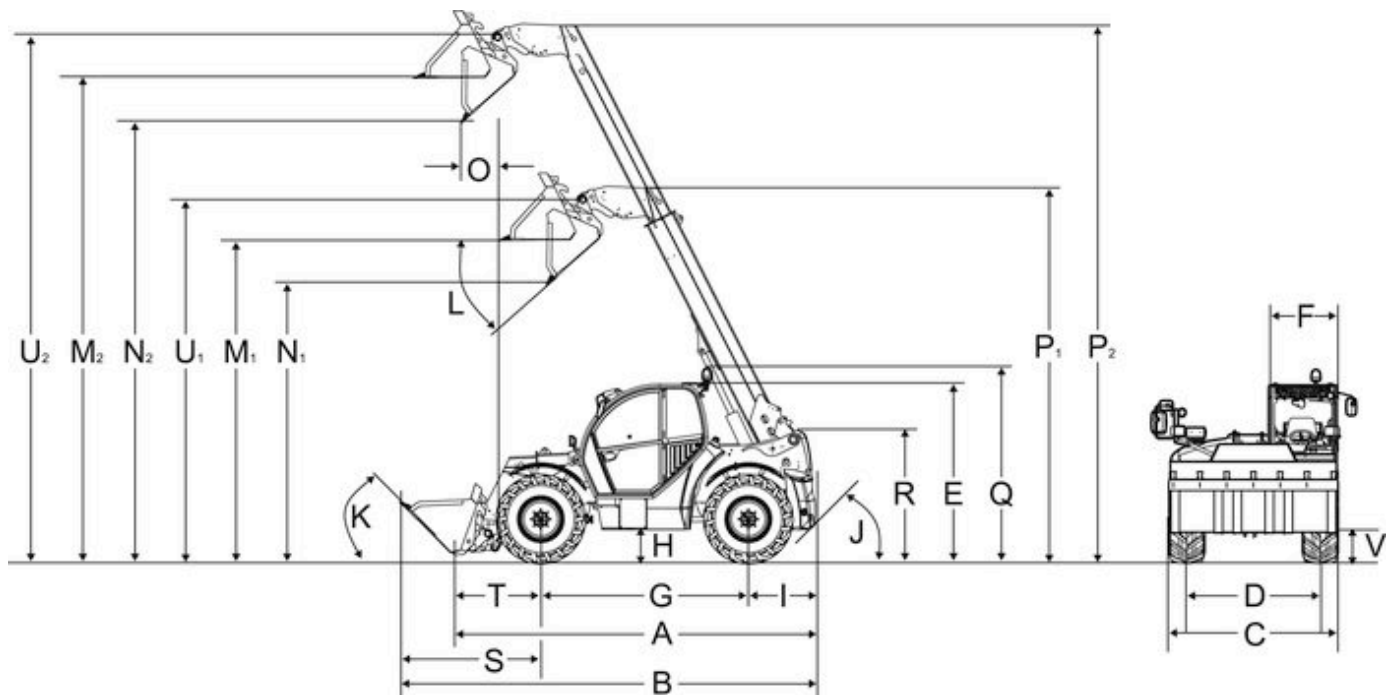

A	Overall length	5,890 mm
B	Overall length with bucket	6,690 mm
C	Overall width without attachment	2,500 mm
D1	Track width front	1,995 mm
D2	Track width rear	2,065 mm
E	Total height	2,570 mm
F	Cabin width	990 mm
G	Wheelbase center	3,150 mm
H	Ground clearance under axle and gearbox	418 mm
I	Distance center of rear wheel to rear	1,340 mm
J	Rear actuation angle	46 °
K	Tipping angle	45 °
L	Tip-out angle	41 °
M1	Overhead loading height - retracted	5,545 mm
M2	Overhead loading height - extended	8,498 mm
N1	Dumping height - retracted	5,015 mm
N2	Dumping height - extended	7,997 mm
O	Dump reach - extended	63 mm
P1	Length	6,277 mm
P2	Length	9,243 mm
Q	Total height with rotating beacon	2,740 mm
R	Total height of the telescopic arm bearing in the frame	1,935 mm
S	Distance from the front wheel center to the front edge of the bucket	2,400 mm
T	Distance from the center of the bearing of the front wheel to the quick-change frame	1,310 mm
U1	Bucket pivot point - retracted	6,116 mm
U2	Bucket pivot point - extended	9,083 mm
V	Transport position with attachment	250 mm
-	Turning radius at the outer edge of the wheels	4,415 mm
-	Entry height, cabin floor	975 mm
-	Turning radius at the outer edge of the bucket	5,650 mm

All statements without guarantee. More detailed information on engine power can be found in the operator's manual and product brochures. Subject to alterations and errors excepted. Applicable also to illustrations.