

KT407

Telehandlers > 4t



KRAMER
on the safe side



4.0 t payload and its compact dimensions of 2.30 m width and 2.31 m height make the KT407 a true all-rounder on any agricultural operation. The many options allow this telehandler to adapt to the most diverse application areas in agriculture. Technically speaking, the KT407 convinces with a 136 hp-strong Deutz 3.6 L4 engine and its high hydraulic performance of 140 l/min.

- The large number of Kramer attachments creates the flexibility required for agricultural operations and the Kramer quickhitch plate facilitates the easy exchange of different attachments.
- The KT407 cabin is characterised by a high level of operator comfort, such as the comfortable operator's seat or the excellent ergonomics of the operator's controls, which is reflected in highly efficient working with minimum exhaustion.
- There are three different steering possibilities with which you can optimally react in every situation; all-wheel steering, front wheel steering and crab steering
- The diverse agricultural applications really reflect the advantages of the continuous ecospeed transmission. An acceleration of up to 40 km/h is possible without changing gears.
- Thanks to the intelligent rpm reduction – Smart Driving (optional) – the machine moves with extreme fuel-efficiency – even at the maximum speed of 40 km/h.

KT407 Technical specifications

Operating data

Max. payload	4,000 kg
Max. stack height	7,000 mm
Payload at max. stack height	2,400 kg
Payload at max. reach	1,500 kg
Stack height at max. payload	4,500 mm
Reach at max. payload	1,750 mm
Max. reach	3,760 mm
Turning radius over tyres	3,840 mm
Operating weight	7,850 kg

Engine / Motor

Engine / Motor manufacturer	Deutz
Type / Model	TCD 3.6 / L4
Engine performance	100 kW
Emission standards stage	V
Exhaust aftertreatment system	DOC + DPF + SCR

Power transmission

Traction drive	Hydrostat
Travel speed	30 km/h
Driving speed (option)	40 km/h
Differential lock	Self-locking differential in the front axle
Standard tires	405/70-24 (AS-tread)

Operating hydraulics

Duty pump	Load-sensing axial piston pump
Max. pump discharge capacity	140 l/min
Max. pump pressure	260 bar

Filling capacities

Fuel tank	100 l
DEF tank	9.5 l
Hydraulic oil tank	100 l

Sound emission

Measured value	104 dB(A)
Guaranteed value	106 dB(A)
Noise level at the driver's ear	76 dB(A)

Vibrations

Total vibrations value of the upper body extremities	< 2.5 m/s ²
Highest effective value of weighted acceleration for the body	< 0.5 m/s ² / 1.28 m/s ²

KT407 Dimensions

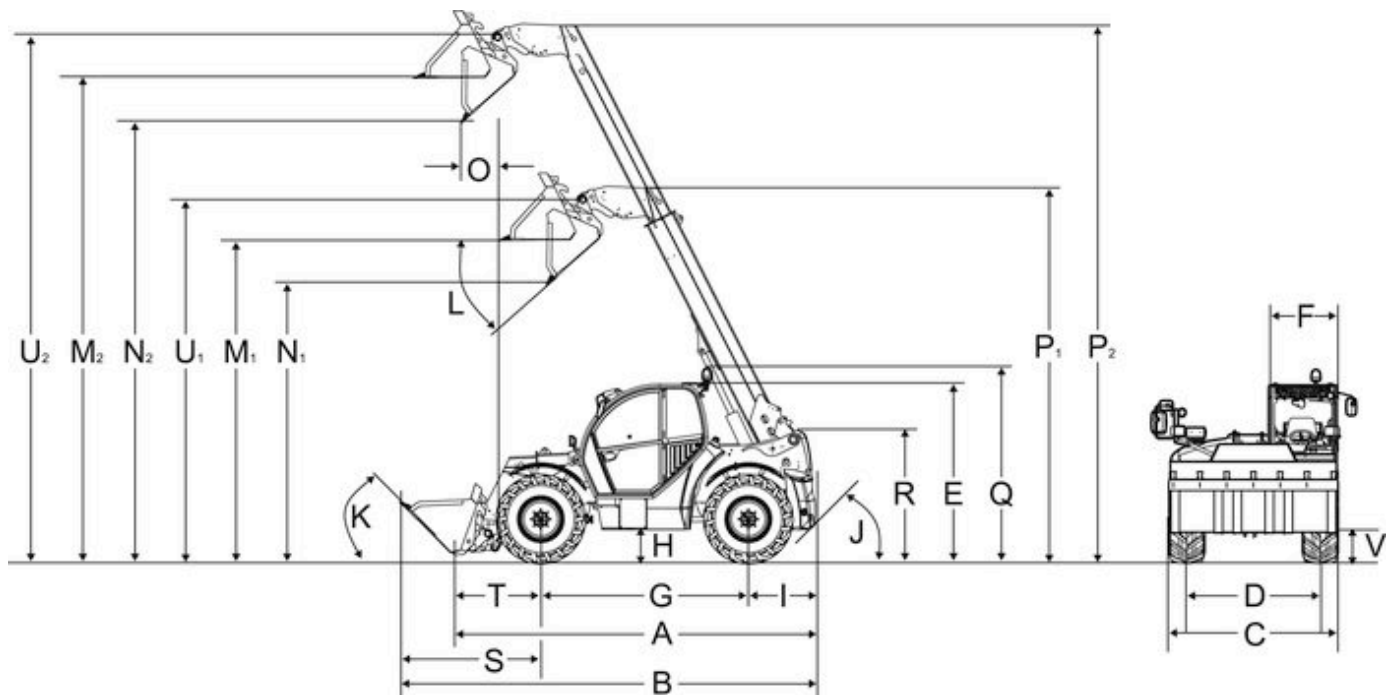

A	Overall length	4,880 mm
B	Overall length with bucket	5,600 mm
C	Overall width without attachment	2,285 mm
D1	Track width front	1,880 mm
D2	Track width rear	1,880 mm
E	Total height	2,310 mm
F	Cabin width	990 mm
G	Wheelbase center	2,850 mm
H	Ground clearance under axle and gearbox	415 mm
I	Distance center of rear wheel to rear	830 mm
J	Rear actuation angle	60 °
K	Tipping angle	49 °
L	Tip-out angle	41 °
M1	Overhead loading height - retracted	4,520 mm
M2	Overhead loading height - extended	6,820 mm
N1	Dumping height - retracted	4,030 mm
N2	Dumping height - extended	6,330 mm
O	Dump reach - extended	110 mm
P1	Length	5,255 mm
P2	Length	7,820 mm
Q	Total height with rotating beacon	2,540 mm
R	Total height of the telescopic arm bearing in the frame	1,600 mm
S	Distance from the front wheel center to the front edge of the bucket	1,920 mm
T	Distance from the center of the bearing of the front wheel to the quick-change frame	1,200 mm
U1	Bucket pivot point - retracted	5,035 mm
U2	Bucket pivot point - extended	7,336 mm
V	Transport position with attachment	250 mm
	Turning radius at the outer edge of the wheels	3,840 mm
	Entry height, cabin floor	720 mm
	Turning radius at the outer edge of the bucket	5,000 mm