

KT357

Telehandlers < 3.5t



KRAMER
on the safe side



The Kramer KT357 is a manoeuvrable, compact and powerful telehandler, which was designed for agricultural work. The maximum lift capacity of 3.5 tonnes and stacking height of 7 metres provides outstanding versatility for all farm and loading activities. The overlapping area between the inner and outer arm > 1 m is another example of its sturdy design. Its 136 hp engine as well as the standard load-sensing hydraulic system provide for performance that you need.

- Lift capacity: 3.5 tonne payload and a stacking height of 7 metres
- Precision: The final position dampening in all 3 functions of the loader unit minimises load losses and ensures even movement sequences
- Sturdy quickhitch plate: Rapid and efficient replacement of attachments
- Compactness: Compact dimensions allow easy operation, even in tight spaces
- Simple operation: Even if it gets later in the day, safe operation is still possible, because all of the elements are backlit.

KT357 Technical specifications

Operating data

Max. payload (LSP 500 mm)	3,500 kg
Max. stack height	7,000 mm
Payload at max. stack height	2,200 kg
Payload bei max. Reichweite	1,200 kg
Stack height at max. payload	5,220 mm
Reach at max. payload	1,680 mm
Max. reach	3,760 mm
Operating weight (max.)	7,620 kg
Total swing angle of tool carrier	155 °
Bucket capacity	1 m ³

Engine / Motor

Engine / Motor manufacturer	Deutz
Type / Model	TCD 3.6 / L4
Engine performance	100 kW
Emission standards stage	V
Exhaust aftertreatment system	DOC + DPF + SCR

Power transmission

Traction drive	Hydrostat
Driving speed (standard)	30 km/h
Driving speed (option)	20 km/h
Driving speed (option)	40 km/h
Differential lock	Self-locking differential 45% in the front axle
Standard tires	405/70-24

Operating hydraulics

Duty pump	Load-Sensing
Max. pump discharge capacity	140 l/min
Max. pump pressure	260 bar

Filling capacities

Fuel tank	100 l
Hydraulic oil tank	100 l
DEF tank	9.5 l

Sound emission

Measured value	105 dB(A)
Guaranteed value	106 dB(A)
Noise level at the driver's ear	72 dB(A)

Vibrations

Total vibrations value of the upper body extremities	< 2,5 m/s ²
Highest effective value of weighted acceleration for the body	< 0,5 m/s ²

KT357 Dimensions

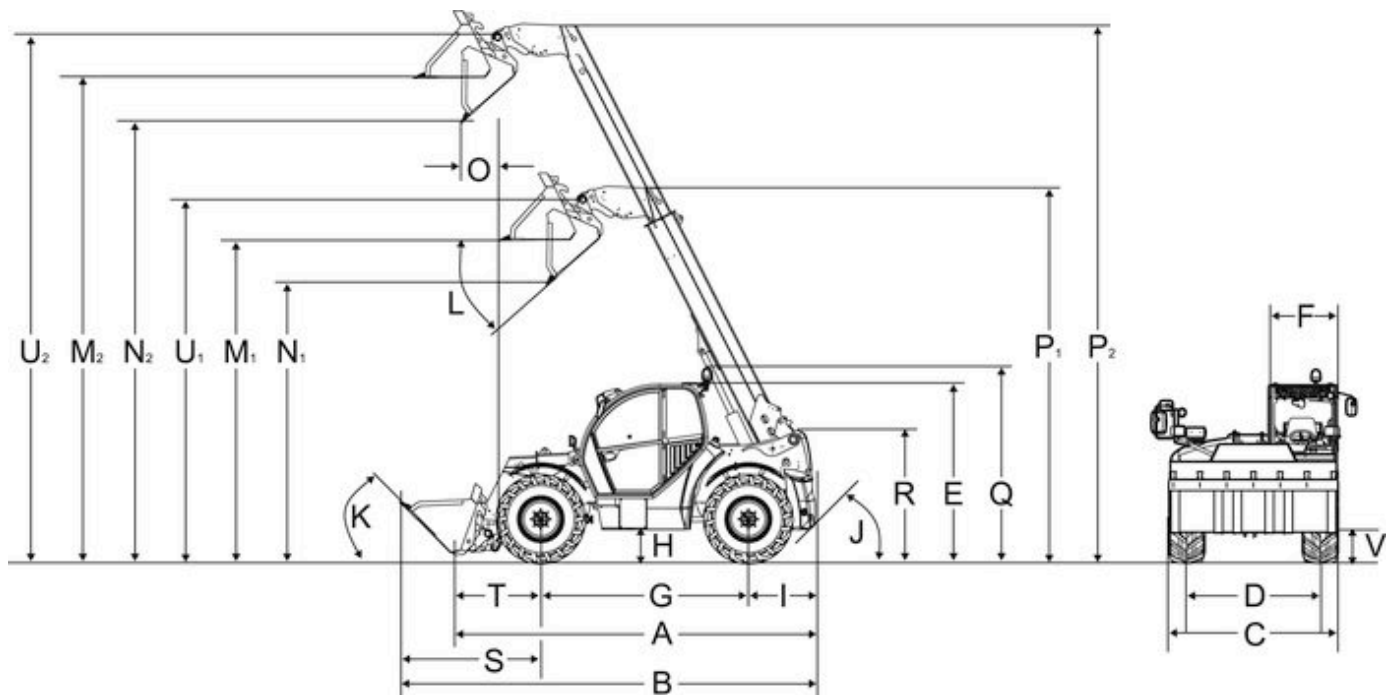

A	Overall length	4,880 mm
B	Overall length with bucket	5,600 mm
C	Overall width without attachment	2,285 mm
D	Track width front	1,880 mm
D	Track width rear	1,880 mm
E	Total height	2,310 mm
F	Cabin width	990 mm
G	Wheelbase center	2,850 mm
H	Ground clearance under axle and gearbox	415 mm
I	Distance center of rear wheel to rear	830 mm
J	Rear actuation angle	45 °
K	Tipping angle	49 °
L	Tip-out angle	41 °
M1	Overhead loading height - retracted	4,520 mm
M2	Overhead loading height - extended	6,820 mm
N1	Dumping height - retracted	4,030 mm
N2	Dumping height - extended	6,330 mm
O	Dump reach - extended	110 mm
P1	Length Tele Auszugslänge - eingefahren	5,255 mm
P2	Length Tele Auszugslänge - ausgefahren	7,820 mm
Q	Total height with rotating beacon	2,540 mm
R	Total height of the telescopic arm bearing in the frame	1,600 mm
S	Distance from the front wheel center to the front edge of the bucket	1,920 mm
T	Distance from the center of the bearing of the front wheel to the quick-change frame	1,200 mm
U1	Bucket pivot point - retracted	5,035 mm
U2	Bucket pivot point - extended	7,335 mm
V	Transport position with attachment	250 mm
-	Turning radius at the outer edge of the wheels	3,840 mm
-	Entry height, cabin floor	720 mm
-	Turning radius at the outer edge of the bucket	5,000 mm