

TRACKED FELLER BUNCHERS/HARVESTERS



JOHN DEERE

803M/MH / 853M/MH / 859M/MH



**PROVEN
PERFORMANCE**



***OUTRUN
EXPECTATIONS.***



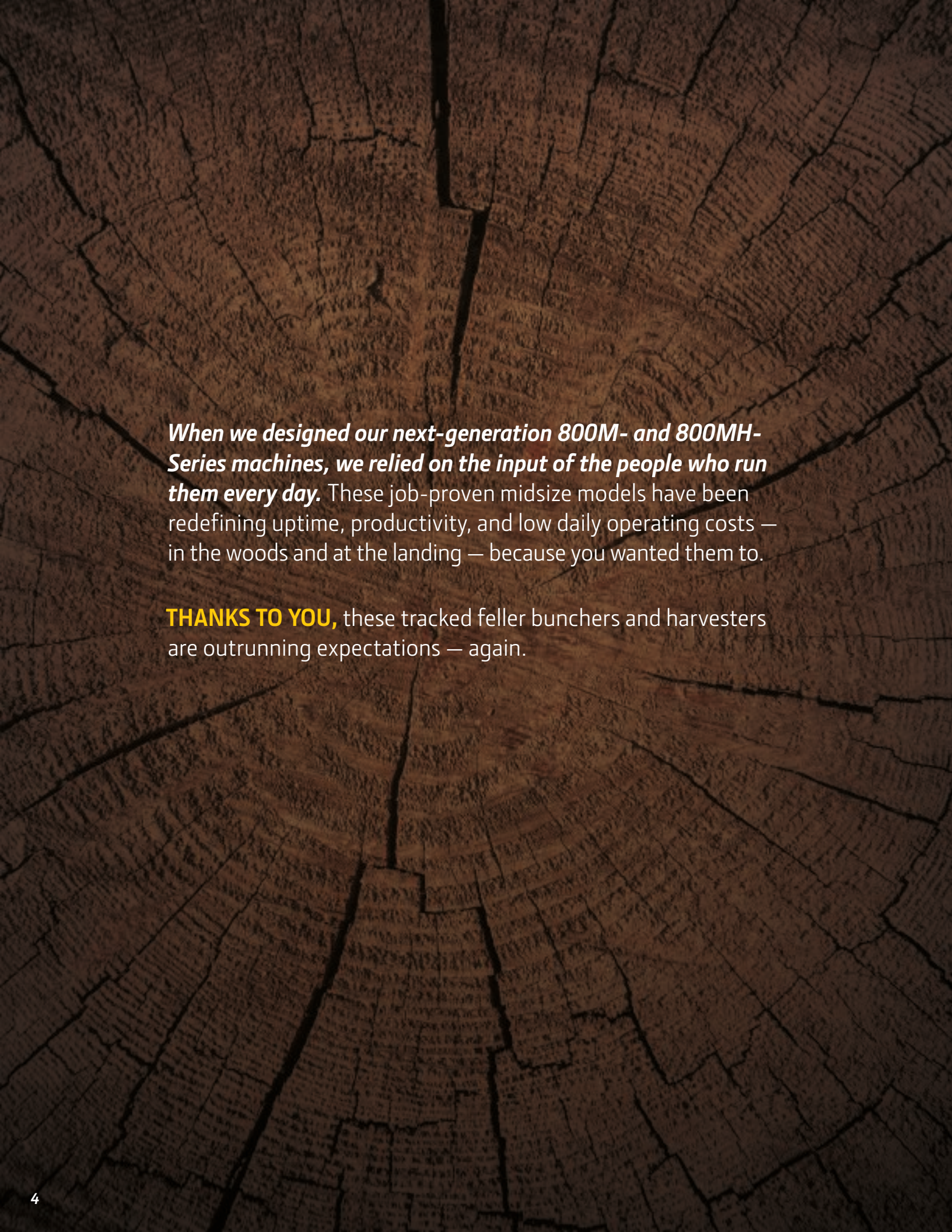

When we designed our next-generation 800M- and 800MH-Series machines, we relied on the input of the people who run them every day. These job-proven midsize models have been redefining uptime, productivity, and low daily operating costs — in the woods and at the landing — because you wanted them to.

THANKS TO YOU, these tracked feller bunchers and harvesters are outrunning expectations — again.

YOU ASKED FOR IT

Built for the way you work.

Ongoing input from Customer Advocate Groups (CAGs) helps make 800M- and 800MH-Series machines even more rugged and reliable.

Reach beyond

New extended stick option (for 800MH models only) enables a longer reach to minimize the number of cut trails and maximize machine efficiency.

Multiple boom-set/ attachment combinations

A variety of boom sets and felling and harvesting attachments can be combined to optimize productivity across a wide range of conditions.

Surefooted stability

Long, wide undercarriage provides solid balance to maximize stability, no matter the terrain.

Get in the swing

Dual swing system increases power and performance in demanding felling or harvesting conditions, boosting overall productivity.

Ample tractive effort

Strong tractive effort generously increases capability for negotiating difficult or steep terrain, deep snow, and swamps.

Smart debris management

Designed to keep your workspace free and clear, the productivity-boosting debris-management system is integrated into the hood and left-side guarding to prevent materials and debris from entering the cooling package. External screening, sealed cooler compartment, and standard variable-speed reversing fan provide cooling protection when and where it's needed.





SAVE TIME



COVER MORE AREA

A yellow harvester head is shown in a forest, holding a large log. The background is a dense forest of tall, thin trees.

MAXIMIZE PRODUCTIVITY

Rapid Cycle System.

Faster, low-effort joystick control of all boom functions helps operators of 800M- and 800MH-Series machines be more productive. Rapid Cycle System (RCS) combines automated felling-head arm cycling with simple boom control — dramatically reducing operator fatigue while increasing efficiency and productivity.

Adaptable to preferences and environments

RCS can be tailored to individual skill levels and specific harvesting conditions, from large single-tree harvesting to high-speed, multi-stem cutting.

Operator-specific settings

Multiple RCS settings can be saved according to individual operator preferences. Novices may prefer a slower, more methodical pace, while highly skilled pros may want faster response.

Selectable operation

Press a single button to engage RCS mode. Conditions don't suit the fast, parallel motion of the boom? Turn RCS off with another touch of a button.

FT4 IN THE FOREST

Cutting-edge solutions.

You asked for the latest technology to meet FT4/ Stage IV emission regulations, and we listened and delivered. In fact, we're always focused on implementing the right engine solutions at the right time — without compromise of power, reliability, or ease of operation.

Fluid-efficient FT4 engines

Our FT4/Stage IV PowerTech™ PSS diesels meet emission regulations without sacrificing power or torque. Built on our EPA Interim Tier 4 (IT4)/EU Stage IIIB solution, this simple technology delivers a winning combination of performance, fluid efficiency, and reliability.

Minimal impact on operation

Under normal operating conditions, the engine's natural heat breaks down trapped particulate matter and cleans the exhaust filter without impacting machine operation. Ash-service intervals for the diesel particulate filter (DPF) are condition based, meaning machine alerts will notify the operator before service is required. Typically, ash service is not necessary until the first engine overhaul depending on machine application, regular maintenance practices, and type of lubricating oil.

Low total fluid consumption

John Deere FT4 engines maintain peak engine performance while minimizing total fluid consumption — diesel fuel plus diesel exhaust fluid (DEF). This exceptionally conservative DEF-use rate is up to four times lower than that of some other FT4 systems.

Up to **4X LOWER**

**DEF-CONSUMPTION RATE
THAN SOME FT4 SYSTEMS**





FT4

EPA FINAL TIER 4 (FT4)/EU STAGE IV
POWERTECH DIESEL ENGINES



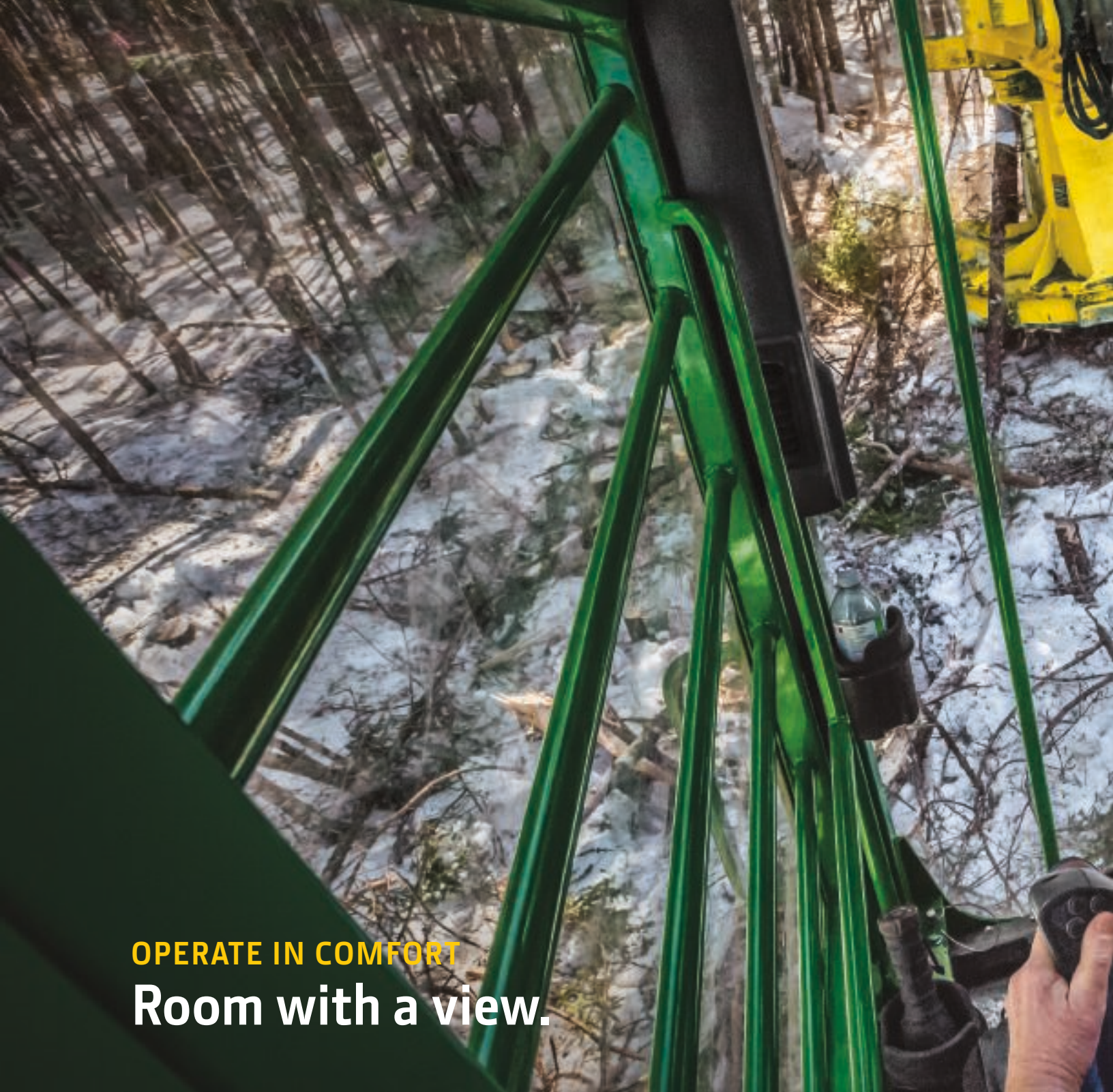

OPERATE IN COMFORT
Room with a view.

Spacious operator station was designed by loggers for loggers. It's roomier and more comfortable, with ergonomically designed controls. And the view has to be seen to be believed, with significantly more window area, for improved visibility.



**10X LONGER-
LASTING**

**MARINE-GRADE
CONTROL CENTER**

Low-effort control

Fully adjustable armrests enable fingertip control of all machine functions on tracked feller bunchers; on tracked harvesters keypads are mounted on the joystick. Fully adjustable air-cushioned seat provides outstanding daylong comfort in the climate-controlled cab.

Sealed-switch module

Sealed touchpad keeps out dust, moisture, and debris, minimizing wear. Proven marine-grade control center eliminates rocker switches, numerous wires, and unsealed connections, and lasts up to 10 times longer than standard dash switches.

Expansive visibility

Floor-to-ceiling front window, large side windows, skylight, and optional floor window (standard on levelers) significantly expand the view of the harvesting area and the work at hand.



EXPECT MORE And then some.

In the woods, uptime is the name of the game. That's why we went to our toughest customers, loggers just like you, to continually reinvent the rugged 800M- and 800MH-Series Tracked Feller Bunchers and Tracked Harvesters. Your latest great idea is a new extended stick option on 800MH models.

More boom

Field-proven boom design is transplanted from our larger 900M- and 900MH-Series models. All booms are robust, with thick plates and strong joints, for extended durability and wear life. Designed for use with smaller attachments, the new extended stick option (only on 800MH models) reaches 9.9 m (32.5 ft.) and features a narrow boom tip to extend past standing timber and cover wider swaths, minimizing damage to harvested trees and easing travel in sensitive areas.

Stable and able

Reliable stability and solid engine horsepower help make quick work of the woods in all conditions.

Larger fuel tanks

Fuel-tank capacity has been increased (to 230 gal. versus 154 on comparably sized machines) to extend intervals between fill-ups.

Through-nose harvester-head plumbing

Through-nose plumbing option routes hoses up and out of harm's way to extend hose wear life, increasing uptime and reducing operating costs.

Optional closed-loop hydrostatic drive

Boost multifunctioning, particularly on slopes and in rough terrain. Adjust priority between track drive and other hydraulic functions to match site conditions and operator preference.

Optional toolbox

Optional undercarriage-mounted toolbox provides convenient storage for tools, saw teeth, additional saw bars, and other spare parts, minimizing trips back to the service truck.



Maratah

TH623C



**JOHN DEERE ULTIMATE UPTIME/
JOHN DEERE FORESTSIGHT™/TIMBERNAVI™**

Save time and money.

As a logger, one of your most valuable commodities is uptime. You need fast, accurate diagnosis of machine issues, rapid service response, and tracking of equipment and operators to maximize efficiency and productivity. We have John Deere forestry solutions to help you do that, and more.



Keep downtime down with
**JOHN DEERE
ULTIMATE UPTIME**

In addition to the base John Deere ForestSight features, our dealers work with you to build an uptime package that meets your specific needs, including customized maintenance and repair agreements, onsite parts availability, extended warranties, fluid sampling, response-time guarantees, and more.

Get valuable insight with
**JOHN DEERE
FORESTSIGHT**

Alerts can be sent to your computer or mobile device — or your Deere dealer, if you choose — to inform you of immediate machine issues. If downtime does occur, exclusive remote diagnostics and programming enable your dealer to minimize the time and cost associated with sending a technician to the logging site for an initial diagnostic visit. You can also receive reminders of periodic scheduled maintenance on your computer or mobile device, or from your dealer.

**More visibility, more
profitability**

TimberNavi is a proven jobsite-mapping solution designed for full-tree logging operations. It gives you in-machine visibility of current position, harvesting area, points of interest, and more. Alarm functionality gives operators increased awareness of cut-block boundaries and hazards, and a 10-in. high-resolution display makes the entire jobsite visible at a glance. By delivering accurate location information in real time, TimberNavi enables operators to navigate confidently and efficiently through the jobsite.

Simplified serviceability

Easy access to service components helps confirm daily checks and preventative maintenance get done on schedule, minimizing costly repairs down the road.

Hydraulic reversing fan

Standard variable-speed reversing fan runs only as fast as the system requires. This conserves power and fuel while blocking debris. To keep the system clean, the fan also reverses on a timed cycle to reverse airflow and eject debris from the cooling cores. If conditions demand more frequent cleaning, the fan can be reversed by a simple push of a button.

Proven components

800M- and 800MH-Series machines share many common components — including the engine, undercarriage, booms, and cab — with their 900M- and 900MH-Series counterparts, for ease of maintenance and repairs when needed.

Remote diagnostics

When equipped with JDLink™, fast, accurate remote diagnostics and rapid service response with the right part the first time, industry-leading parts availability, and dealer support are always within easy reach.

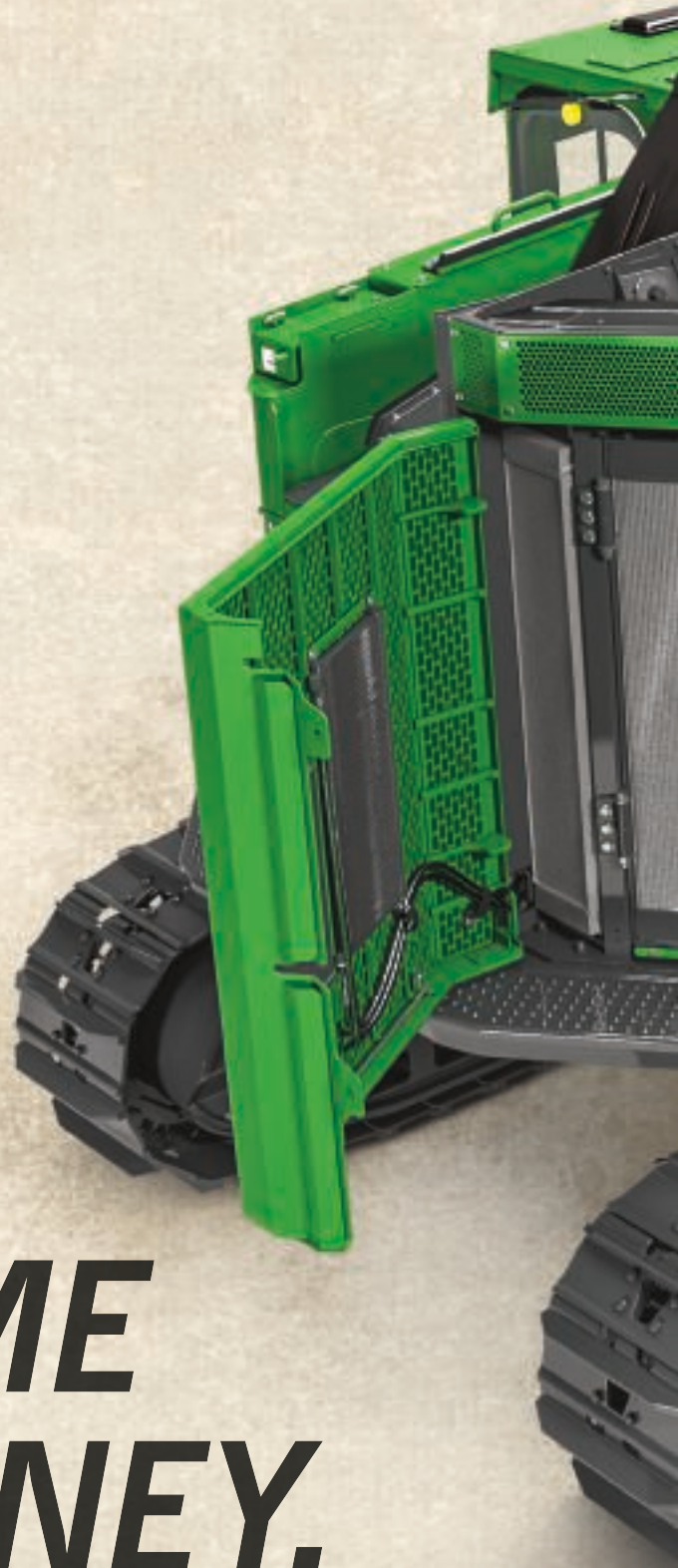

SAVE TIME AND MONEY.



WARNING 

KEEP BACK 300FT/90M

IPS 210

803M/853M/859M

Engine	803M/853M		859M with Standard Travel		859M with Dedicated Travel	
Manufacturer and Model	John Deere PowerTech™ PSS 9.0L		John Deere PowerTech PSS 9.0L		John Deere PowerTech PSS 9.0L	
Non-Road Emission Standard	EPA Final Tier 4/EU Stage IV		EPA Final Tier 4/EU Stage IV		EPA Final Tier 4/EU Stage IV	
Cylinders	6		6		6	
Displacement	9.0 L (549 cu. in.)		9.0 L (549 cu. in.)		9.0 L (549 cu. in.)	
Peak Power at 1,900 rpm	224 kW (300 hp)		224 kW (300 hp)		246 kW (330 hp)	
Rated Power at 2,000 rpm	213 kW (286 hp)		213 kW (286 hp)		230 kW (308 hp)	
Net Peak Torque at 1,500 rpm	1270 Nm (937 lb.-ft.)		1270 Nm (937 lb.-ft.)		1392 Nm (1,027 lb.-ft.)	
Cooling	803M/853M/859M					
Fan Type	Suction type, hydraulically driven, variable speed, reversing					
Hydraulics	Closed center, load sense, pressure compensated					
Standard Travel System						
Main Pump	Variable-displacement axial piston					
Maximum Rated Flow	494 L/min. (131 gpm)					
Continuous Saw Pump	Dedicated variable-displacement axial piston					
Maximum Rated Flow	135 L/min. (36 gpm)					
Attachment Pump	Dedicated variable-displacement axial piston					
Maximum Rated Flow	135 L/min. (36 gpm)					
Dedicated Travel System						
Main Pump	Variable-displacement axial piston					
Maximum Rated Flow	494 L/min. (131 gpm)					
Travel Pump	Dedicated variable-displacement axial piston					
Maximum Rated Flow (x2)	190 L/min. (50 gpm)					
Continuous Saw Pump	Dedicated variable-displacement axial piston					
Maximum Rated Flow	135 L/min. (36 gpm)					
Attachment Pump	Dedicated variable-displacement axial piston					
Maximum Rated Flow	135 L/min. (36 gpm)					
Oil Filtration	2 main return filters, 10-micron return with bypass, one case drain strainer, 25 micron					
Electrical						
Voltage	24 volt					
Number of Batteries	2 x 12 volt					
Alternator Rating	200 amp					
Work Lights						
Standard	Halogen (9 flood, 3 spot)					
Optional	LED (5 flood, 3 spot); halogen (4 flood)					
Service Lights	Halogen (2)					
Undercarriage	803M	853M		859M		
Integral track guides, thick high-abrasion-resistant material, ramp angles, hydraulic track adjustment						
Size	U6 Extreme Duty (EXD)		U7 EXD		U7L EXD	
Track Chain	203.2 mm (8 in.)		215.9 mm (8.5 in.)		215.9 mm (8.5 in.)	
Number of Track Links (per side)	47		47		47	
Lower Rollers (per side)	9		9		10	
Carrier Slides/Rollers (per side)	2		2		2	
Travel Performance	<i>Standard Travel</i>	<i>Dedicated Travel</i>	<i>Standard Travel</i>	<i>Dedicated Travel</i>	<i>Standard Travel</i>	<i>Dedicated Travel</i>
Travel Speed, Forward and Reverse						
High	4.6 km/h (2.9 mph)	4.8 km/h (3.0 mph)	4.3 km/h (2.6 mph)	4.1 km/h (2.6 mph)	3.7 km/h (2.3 mph)	3.7 km/h (2.3 mph)
Low	2.8 km/h (1.7 mph)	2.7 km/h (1.7 mph)	2.0 km/h (1.2 mph)	2.0 km/h (1.2 mph)	1.6 km/h (1.0 mph)	1.7 km/h (1.0 mph)
Tractive Effort	245 kN (55,078 lbf)	245 kN (55,040 lbf)	322 kN (72,389 lbf)	322 kN (72,389 lbf)	373 kN (83,854 lbf)	384 kN (86,327 lbf)
Rotating Upper						
Swing System	<i>Standard</i>	<i>Optional</i>	<i>Standard</i>	<i>Standard</i>		
Swing Speed (maximum)	7.7 rpm	6.8 rpm	6.8 rpm	6.8 rpm		
Swing Torque	55 090 Nm (40,630 lb.-ft.)	94 740 Nm (69,880 lb.-ft.)	94 740 Nm (69,880 lb.-ft.)	94 740 Nm (69,880 lb.-ft.)		
Swing Brake	Sealed wet multi-disc, manually applied/released					
Serviceability	803M/853M/859M					
Refill Capacities						
Fuel Tank	870 L (230 gal.)					
Diesel Exhaust Fluid (DEF)	30.7 L (8.1 gal.)					



Ground Pressure (SAE J1309)	803M	853M	859M
Includes standard equipment, 6.71-m boom, half-full fuel tank, and all fluids, less attachment			
Undercarriage	U6 EXD	U7 EXD	U7L EXD
Counterweight	Standard	Medium	Standard
Boom	Standard with Rapid Cycle System (RCS)	Power with RCS	Power with RCS
Double Grouser			
610 mm (24 in.)	59.8 kPa (8.7 psi)	60.6 kPa (8.8 psi)	69.4 kPa (10.1 psi)
762 mm (30 in.)	51.9 kPa (7.5 psi)	50.8 kPa (7.4 psi)	N/A
Single Grouser			
610 mm (24 in.)	59.4 kPa (8.6 psi)	60.4 kPa (8.8 psi)	69.3 kPa (10.1 psi)
711 mm (28 in.)	51.5 kPa (7.5 psi)	52.5 kPa (7.6 psi)	60.1 kPa (8.7 psi)
Triple Grouser (soft terrain only)			
914 mm (36 in.)	41.5 kPa (6.0 psi)	43.2 kPa (6.3 psi)	N/A

Operating Weight	803M	853M	859M
Includes standard equipment, 6.71-m boom, 610-mm (24 in.) single-grouser tracks, half-full fuel tank, and all fluids, less attachment			
Undercarriage	U6 EXD	U7 EXD	U7L EXD
Counterweight	Standard	Medium	Standard
Boom	Standard with RCS	Power with RCS	Power with RCS
Approximate Weight — Base Machine	29 030 kg (64,010 lb.)	31 600 kg (69,680 lb.)	36 060 kg (79,510 lb.)

Boom Performance	803M	853M	859M
6.71-m Boom			
Maximum Reach (to tip of saw blade)	8.49 m (27 ft. 10 in.)	8.49 m (27 ft. 10 in.)	8.49 m (27 ft. 10 in.)
Minimum Reach (to tip of saw blade)	3.83 m (12 ft. 7 in.)	3.83 m (12 ft. 7 in.)	3.83 m (12 ft. 7 in.)
Cutting Swath	4.66 m (15 ft. 3 in.)	4.66 m (15 ft. 3 in.)	4.66 m (15 ft. 3 in.)
Lift Option with RCS	<i>Standard</i>	<i>Power</i>	<i>Power</i>
Lift Capacity, Bare Pin at Full Reach	4400 kg (9,700 lb.)	5540 kg (12,220 lb.)	5540 kg (12,220 lb.)
Lift Capacity, Bare Pin at 6.1 m (20 ft.)	5520 kg (12,170 lb.)	6860 kg (15,130 lb.)	6860 kg (15,130 lb.)
Lift Capacity, Bare Pin at 4.6 m (15 ft.)	7990 kg (17,620 lb.)	9770 kg (21,540 lb.)	9770 kg (21,540 lb.)
6.1-m Boom			
Maximum Reach (to tip of saw blade)	7.88 m (25 ft. 10 in.)	7.88 m (25 ft. 10 in.)	7.88 m (25 ft. 10 in.)
Minimum Reach (to tip of saw blade)	3.92 m (12 ft. 10 in.)	3.92 m (12 ft. 10 in.)	3.92 m (12 ft. 10 in.)
Cutting Swath	3.96 m (13 ft. 0 in.)	3.96 m (13 ft. 0 in.)	3.96 m (13 ft. 0 in.)
Lift Option with RCS	<i>Standard</i>	<i>Power</i>	<i>Power</i>
Lift Capacity, Bare Pin at 6.1 m (20 ft.) at Full Reach	4830 kg (10,650 lb.)	6670 kg (14,710 lb.)	6670 kg (14,710 lb.)
Lift Capacity, Bare Pin at 4.6 m (15 ft.)	7840 kg (17,290 lb.)	10 510 kg (23,170 lb.)	10 510 kg (23,170 lb.)

803M and 853M Tracked Feller Bunchers

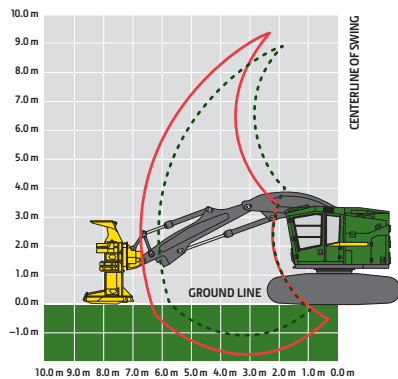

859M Tracked Feller Buncher

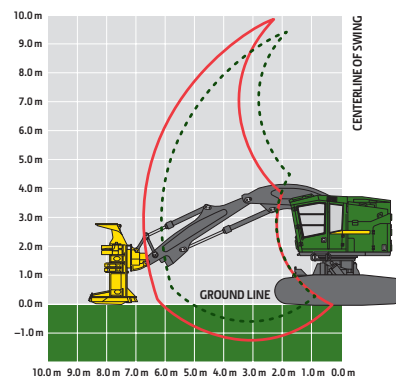

Attachment Information	FS20	FR21B	FS22B	FR22B	FR24B
Attachment	803M	803M, 853M, 859M	803M, 853M, 859M	803M, 853M, 859M	853M, 859M
Models	803M	803M, 853M, 859M	803M, 853M, 859M	803M, 853M, 859M	853M, 859M
Maximum Cutting Capacity	559 mm (22.0 in.)	545 mm (21.5 in.)	559 mm (22.0 in.)	559 mm (22.0 in.)	622 mm (24.5 in.)
Maximum Accumulation Capacity	0.43 m ² (4.6 sq. ft.)	0.46 m ² (5.0 sq. ft.)	0.48 m ² (5.2 sq. ft.)	0.48 m ² (5.2 sq. ft.)	0.60 m ² (6.5 sq. ft.)
Opening at Front of Housing	983 mm (38.7 in.)	1180 mm (46.5 in.)	1280 mm (50.4 in.)	1280 mm (50.4 in.)	1372 mm (54.0 in.)
Blade Diameter	1422 mm (56.0 in.)	1372 mm (54.0 in.)	1422 mm (56.0 in.)	1422 mm (56.0 in.)	1549 mm (61.0 in.)
Number of Teeth	18	18	18	18	20
Saw rpm	1,150 rpm	1,150 rpm	1,150 rpm	1,150 rpm	1,150 rpm
Wrist Rotation	30 deg.	302 deg.	30 deg.	312 deg.	310 deg.
Width at Saw Housing	1600 mm (63.0 in.)	1550 mm (61.0 in.)	1620 mm (63.8 in.)	1620 mm (63.8 in.)	1737 mm (68.4 in.)
Height	2794 mm (110.0 in.)	2820 mm (111.0 in.)	3068 mm (120.8 in.)	3068 mm (120.8 in.)	3068 mm (120.8 in.)
Weight (including adapter and wrist)	2650 kg (5,840 lb.)	3140 kg (6,920 lb.)	3550 kg (7,830 lb.)	3840 kg (8,470 lb.)	4020 kg (8,860 lb.)

803M/853M/859M

Machine Dimensions	803M	853M	859M
Standard Undercarriage	U6 EXD	U7 EXD	U7L EXD
A Overall Height with Standard 6.71-m Boom			
Top of Cab with Flat Skylight	3.43 m (11 ft. 3 in.)	3.46 m (11 ft. 4 in.)	3.92 m (12 ft. 10 in.)
Top of Cab with Peaked Skylight	3.65 m (12 ft. 0 in.)	3.68 m (12 ft. 1 in.)	4.13 m (13 ft. 7 in.)
Top of Boom, Extended, Attachment Vertical	3.89 m (12 ft. 9 in.)	3.93 m (12 ft. 11 in.)	4.15 m (13 ft. 7 in.)
B Overall Track Length	4.61 m (15 ft. 1 in.)	4.90 m (16 ft. 1 in.)	4.90 m (16 ft. 1 in.)
C Track Length (idler to sprocket center)	3.57 m (11 ft. 9 in.)	3.83 m (12 ft. 7 in.)	3.83 m (12 ft. 7 in.)
D Tail Swing (from swing center)			
Small and Medium Counterweight	1.94 m (6 ft. 4 in.)	1.94 m (6 ft. 4 in.)	1.94 m (6 ft. 4 in.)
Medium Extended and Large Extended Counterweight	2.25 m (7 ft. 4 in.)	2.25 m (7 ft. 4 in.)	2.25 m (7 ft. 4 in.)
E Boom Reach (to attachment pin)			
Standard 6.71-m Boom			
Maximum	6.71 m (22 ft. 0 in.)	6.71 m (22 ft. 0 in.)	6.71 m (22 ft. 0 in.)
Minimum	2.05 m (6 ft. 9 in.)	2.05 m (6 ft. 9 in.)	2.05 m (6 ft. 9 in.)
Cutting Swath	4.66 m (15 ft. 3 in.)	4.66 m (15 ft. 3 in.)	4.66 m (15 ft. 3 in.)
Optional 6.10-m Boom			
Maximum	6.10 m (20 ft. 0 in.)	6.10 m (20 ft. 0 in.)	6.10 m (20 ft. 0 in.)
Minimum	2.14 m (7 ft. 0 in.)	2.14 m (7 ft. 0 in.)	2.14 m (7 ft. 0 in.)
Cutting Swath	3.96 m (13 ft. 0 in.)	3.96 m (13 ft. 0 in.)	3.96 m (13 ft. 0 in.)
F Ground Clearance			
Single Grouser	744 mm (29 in.)	779 mm (31 in.)	746 mm (29 in.)
Double Grouser	715 mm (28 in.)	756 mm (30 in.)	722 mm (28 in.)
Triple Grouser	700 mm (28 in.)	738 mm (29 in.)	N/A
G Upperstructure Width			
Standard	3.15 m (10 ft. 4 in.)	3.15 m (10 ft. 4 in.)	3.15 m (10 ft. 4 in.)
With Optional Walkway	3.36 m (11 ft. 0 in.)	3.36 m (11 ft. 0 in.)	3.36 m (11 ft. 0 in.)
H Track Gauge	2.67 m (8 ft. 9 in.)	2.69 m (8 ft. 10 in.)	2.72 m (8 ft. 11 in.)
I Width Over Tracks			
610-mm (24 in.) Track Shoes	3.28 m (10 ft. 9 in.)	3.30 m (10 ft. 10 in.)	3.33 m (10 ft. 11 in.)
711-mm (28 in.) Track Shoes	3.38 m (11 ft. 1 in.)	3.40 m (11 ft. 2 in.)	3.43 m (11 ft. 3 in.)
760-mm (30 in.) Track Shoes	3.43 m (11 ft. 3 in.)	3.45 m (11 ft. 4 in.)	N/A
914-mm (36 in.) Track Shoes	3.58 m (11 ft. 9 in.)	3.61 m (11 ft. 10 in.)	N/A

859M Leveling

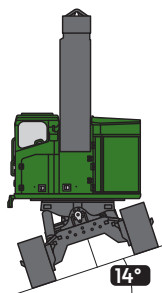
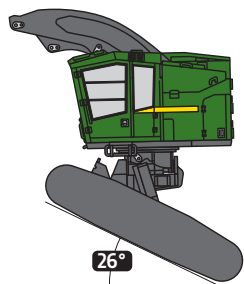

859M Undercarriage-Leveling Mechanism

Forward	26 deg.
Side to Side	14 deg.
Rearward	7 deg.

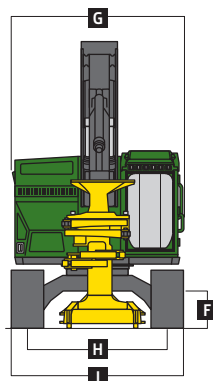

803M/853M Tracked Feller Bunchers

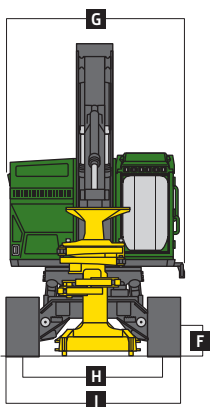
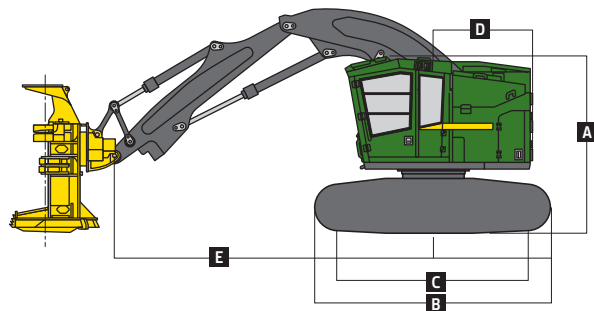

859M Tracked Feller Buncher

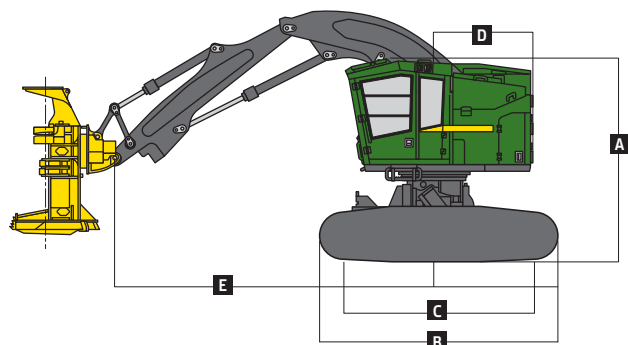

Machine not exactly as shown. Illustrations for dimensioning purposes only. Specifications are subject to change without notice.

803MH/853MH/859MH

Engine	803MH/853MH		859MH with Standard Travel		859MH with Dedicated Travel	
Manufacturer and Model	John Deere PowerTech™ PSS 9.0L		John Deere PowerTech PSS 9.0L		John Deere PowerTech PSS 9.0L	
Non-Road Emission Standard	EPA Final Tier 4/EU Stage IV		EPA Final Tier 4/EU Stage IV		EPA Final Tier 4/EU Stage IV	
Cylinders	6		6		6	
Displacement	9.0 L (549 cu. in.)		9.0 L (549 cu. in.)		9.0 L (549 cu. in.)	
Peak Power at 1,900 rpm	224 kW (300 hp)		224 kW (300 hp)		246 kW (330 hp)	
Rated Power at 2,000 rpm	213 kW (286 hp)		213 kW (286 hp)		230 kW (308 hp)	
Net Peak Torque at 1,500 rpm	1270 Nm (937 lb.-ft.)		1270 Nm (937 lb.-ft.)		1392 Nm (1,027 lb.-ft.)	
Cooling	803MH/853MH/859MH					
Fan Type	Suction type, hydraulically driven, variable speed, reversing					
Hydraulics						
Closed center, load sense, pressure compensated						
Standard Travel System						
Main Pump	Variable-displacement axial piston					
Maximum Rated Flow	494 L/min. (131 gpm)					
Attachment Pump	Dedicated variable-displacement axial piston					
Maximum Rated Flow (x2)	209 L/min. (55 gpm)					
Dedicated Travel System						
Main Pump	Variable-displacement axial piston					
Maximum Rated Flow	494 L/min. (131 gpm)					
Travel Pump	Dedicated variable-displacement axial piston					
Maximum Rated Flow (x2)	190 L/min. (50 gpm)					
Attachment Pump	Dedicated variable-displacement axial piston					
Maximum Rated Flow (x2)	181 L/min. (48 gpm)					
Oil Filtration	2 main return filters, 10-micron return with bypass, one case drain strainer, 25 micron					
Electrical						
Voltage	24 volt					
Number of Batteries	2 x 12 volt					
Alternator Rating	200 amp					
Work Lights						
Standard	Halogen (9 flood, 3 spot)					
Optional	LED (5 flood, 3 spot); halogen (4 flood)					
Service Lights	Halogen (2)					
Undercarriage	803MH		853MH		859MH	
Integral track guides, thick high-abrasion-resistant material, ramp angles, hydraulic track adjustment						
Size	U6 Extreme Duty (EXD)		U7 EXD		U7L EXD	
Track Chain	203.2 mm (8 in.)		215.9 mm (8.5 in.)		215.9 mm (8.5 in.)	
Number of Track Links (per side)	47		47		47	
Lower Rollers (per side)	9		9		10	
Carrier Slides/Rollers (per side)	2		2		2	
Travel Performance	<i>Standard Travel</i>	<i>Dedicated Travel</i>	<i>Standard Travel</i>	<i>Dedicated Travel</i>	<i>Standard Travel</i>	<i>Dedicated Travel</i>
Travel Speed, Forward and Reverse						
High	4.6 km/h (2.9 mph)	4.8 km/h (3.0 mph)	4.3 km/h (2.6 mph)	4.1 km/h (2.6 mph)	3.6 km/h (2.2 mph)	3.7 km/h (2.3 mph)
Low	2.8 km/h (1.7 mph)	2.7 km/h (1.7 mph)	2.0 km/h (1.2 mph)	2.0 km/h (1.2 mph)	1.7 km/h (1.0 mph)	1.7 km/h (1.0 mph)
Tractive Effort	245 kN (55,078 lbf)	245 kN (55,040 lbf)	322 kN (72,389 lbf)	322 kN (72,389 lbf)	373 kN (83,876 lbf)	384 kN (86,327 lbf)
Rotating Upper	803MH/853MH/859MH					
Swing System, Standard						
Swing Speed (maximum)	6.8 rpm					
Swing Torque	94 740 Nm (69,880 lb.-ft.)					
Swing Brake	Sealed wet multi-disc, manually applied/released					
Serviceability						
Refill Capacities						
Fuel Tank	870 L (230 gal.)					
Diesel Exhaust Fluid (DEF)	30.7 L (8.1 gal.)					

803MH/853MH/859MH

Ground Pressure (SAE J1309)	803MH	853MH	859MH
Includes standard equipment, half-full fuel tank, and all fluids, less attachment			
Undercarriage	U6 EXD	U7 EXD	U7L EXD
Counterweight	Standard	Medium	Standard
Boom	8.84 m	7.75 m	7.75 m with RCS
Double Grouser			
610 mm (24 in.)	58.1 kPa (8.4 psi)	58.2 kPa (8.4 psi)	67.0 kPa (9.7 psi)
762 mm (30 in.)	50.5 kPa (7.3 psi)	48.9 kPa (7.1 psi)	N/A
Single Grouser			
610 mm (24 in.)	57.7 kPa (8.4 psi)	58.0 kPa (8.4 psi)	66.8 kPa (9.7 psi)
711 mm (28 in.)	50.1 kPa (7.3 psi)	50.5 kPa (7.3 psi)	58.0 kPa (8.4 psi)
Triple Grouser (soft terrain only)			
914 mm (36 in.)	40.4 kPa (5.9 psi)	41.6 kPa (6.0 psi)	N/A
Operating Weight			
Includes standard equipment, 610-mm (24 in.) single-grouser tracks, half-full fuel tank, and all fluids, less attachment			
Undercarriage	U6 EXD	U7 EXD	U7L EXD
Counterweight	Standard	Medium	Standard
Boom	8.84 m	7.75 m	7.75 m with RCS
Approximate Weight — Base Machine	28 230 kg (62,250 lb.)	30 320 kg (66,860 lb.)	34 800 kg (76,730 lb.)
Boom Performance			
9.91-m Boom			
Lift Option with RCS			
Lift Capacity, Bare Pin at 9.91 m (32 ft. 6 in.) at Full Reach	3500 kg (7718 lb.)	3500 kg (7718 lb.)	3500 kg (7718 lb.)
Lift Capacity, Bare Pin at 6.1 m (20 ft.)	8130 kg (17,927 lb.)	8130 kg (17,927 lb.)	8130 kg (17,927 lb.)
8.84-m Boom			
Lift Option with RCS			
Lift Capacity, Bare Pin at Full Reach	4190 kg (9,240 lb.)	4190 kg (9,240 lb.)	4190 kg (9,240 lb.)
Lift Capacity, Bare Pin at 7.62 m (25 ft.)	5850 kg (12,900 lb.)	5850 kg (12,900 lb.)	5850 kg (12,900 lb.)
Lift Capacity, Bare Pin at 6.1 m (20 ft.)	7700 kg (16,980 lb.)	7700 kg (16,980 lb.)	7700 kg (16,980 lb.)
7.75-m Boom			
Lift Option with RCS			
Lift Capacity, Bare Pin at 7.62 m (25 ft.) at Full Reach	5520 kg (12,170 lb.)	5520 kg (12,170 lb.)	5520 kg (12,170 lb.)
Lift Capacity, Bare Pin at 6.1 m (20 ft.)	8350 kg (18,410 lb.)	8350 kg (18,410 lb.)	8350 kg (18,410 lb.)

803MH and 853MH Tracked Harvesters

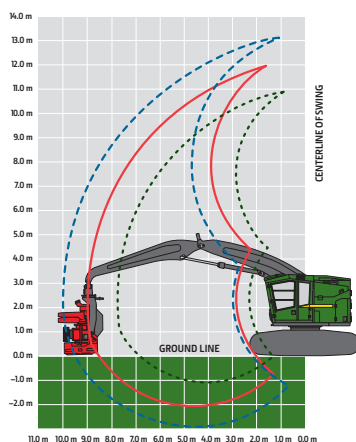

859MH Tracked Harvester

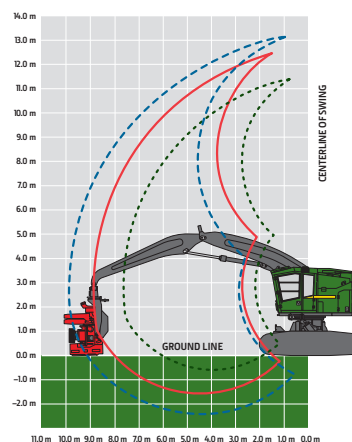

Attachment Information				
Attachment	HTH616C	HTH622B	HTH623C	HTH624C
Models	803MH, 853MH, 859MH	803MH, 853MH, 859MH	803MH, 853MH, 859MH	853MH, 859MH
Maximum Cutting Capacity	550 mm (21.7 in.)	750 mm (29.5 in.)	750 mm (29.5 in.)	810 mm (31.9 in.)
Maximum Delimiting Capacity	510 mm (20.1 in.)	640 mm (25.2 in.)	700 mm (27.6 in.)	760 mm (29.9 in.)
Feeding Mechanism	3 rollers, fully synchronized hydraulic drive		3 rollers, fully synchronized hydraulic drive	
Dimensions				
Maximum Width (arms open)	1600 mm (63.0 in.)	1700 mm (66.9 in.)	2000 mm (78.7 in.)	2000 mm (78.7 in.)
Height (including rotator)	2350 mm (92.5 in.)	2700 mm (106.3 in.)	3000 mm (118.1 in.)	3000 mm (118.1 in.)
Weight (rotator and standard link)	1870 kg (4,120 lb.)	2190 kg (4,830 lb.)	2870 kg (6,330 lb.)	3460 kg (7,630 lb.)

(See individual Harvesting Head brochure for more details.)

803MH/853MH/859MH

Machine Dimensions	803MH	853MH	859MH
Standard Undercarriage	U6 EXD	U7 EXD	U7L EXD
A Overall Height with 8.84-m Boom			
Top of Cab with Flat Skylight	3.43 m (11 ft. 3 in.)	3.46 m (11 ft. 4 in.)	3.92 m (12 ft. 10 in.)
Top of Cab with Peaked Skylight	3.65 m (12 ft. 0 in.)	3.68 m (12 ft. 1 in.)	4.13 m (13 ft. 7 in.)
Top of Boom, Extended, Attachment Vertical	4.45 m (14 ft. 7 in.)	4.45 m (14 ft. 7 in.)	4.70 m (15 ft. 5 in.)
B Overall Track Length	4.61 m (15 ft. 1 in.)	4.90 m (16 ft. 1 in.)	4.90 m (16 ft. 1 in.)
C Track Length (idler to sprocket center)	3.57 m (11 ft. 9 in.)	3.83 m (12 ft. 7 in.)	3.83 m (12 ft. 7 in.)
D Tail Swing (from swing center)			
Small and Medium Counterweight	1.94 m (6 ft. 4 in.)	1.94 m (6 ft. 4 in.)	1.94 m (6 ft. 4 in.)
Medium Extended Counterweight	2.25 m (7 ft. 4 in.)	2.25 m (7 ft. 4 in.)	2.25 m (7 ft. 4 in.)
E Boom Reach (to attachment pin)			
Optional 9.91-m Boom			
Maximum	9.91 m (32 ft. 6 in.)	9.91 m (32 ft. 6 in.)	9.91 m (32 ft. 6 in.)
Minimum	3.45 m (11 ft. 4 in.)	3.45 m (11 ft. 4 in.)	3.45 m (11 ft. 4 in.)
Cutting Swath	6.46 m (21 ft. 2 in.)	6.46 m (21 ft. 2 in.)	6.46 m (21 ft. 2 in.)
Standard 8.84-m Boom			
Maximum	8.84 m (29 ft. 0 in.)	8.84 m (29 ft. 0 in.)	8.84 m (29 ft. 0 in.)
Minimum	2.71 m (8 ft. 11 in.)	2.71 m (8 ft. 11 in.)	2.71 m (8 ft. 11 in.)
Cutting Swath	6.13 m (20 ft. 1 in.)	6.13 m (20 ft. 1 in.)	6.13 m (20 ft. 1 in.)
Optional 7.75-m Boom			
Maximum	7.75 m (25 ft. 5 in.)	7.75 m (25 ft. 5 in.)	7.75 m (25 ft. 5 in.)
Minimum	2.31 m (7 ft. 7 in.)	2.31 m (7 ft. 7 in.)	2.31 m (7 ft. 7 in.)
Cutting Swath	5.44 m (17 ft. 10 in.)	5.44 m (17 ft. 10 in.)	5.44 m (17 ft. 10 in.)
F Ground Clearance			
Single Grouser	744 mm (29 in.)	779 mm (31 in.)	748 mm (29 in.)
Double Grouser	715 mm (28 in.)	756 mm (30 in.)	725 mm (29 in.)
Triple Grouser	700 mm (28 in.)	738 mm (29 in.)	N/A
G Upperstructure Width			
Standard	3.15 m (10 ft. 4 in.)	3.15 m (10 ft. 4 in.)	3.15 m (10 ft. 4 in.)
With Optional Walkway	3.36 m (11 ft. 0 in.)	3.36 m (11 ft. 0 in.)	3.36 m (11 ft. 0 in.)
H Track Gauge	2.67 m (8 ft. 9 in.)	2.69 m (8 ft. 10 in.)	2.72 m (8 ft. 11 in.)
I Width Over Tracks			
610-mm (24 in.) Track Shoes	3.28 m (10 ft. 9 in.)	3.30 m (10 ft. 10 in.)	3.33 m (10 ft. 11 in.)
711-mm (28 in.) Track Shoes	3.38 m (11 ft. 1 in.)	3.40 m (11 ft. 2 in.)	3.43 m (11 ft. 3 in.)
760-mm (30 in.) Track Shoes	3.43 m (11 ft. 3 in.)	3.45 m (11 ft. 4 in.)	N/A
914-mm (36 in.) Track Shoes	3.58 m (11 ft. 9 in.)	3.61 m (11 ft. 10 in.)	N/A

859MH Leveling

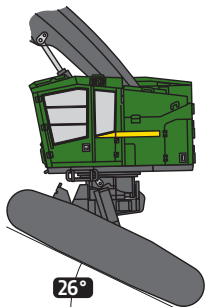

26°

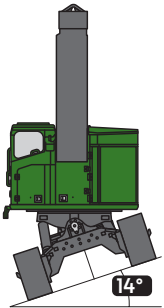

14°

859MH Undercarriage-Leveling Mechanism

Forward	26 deg.
Side to Side	14 deg.
Rearward	7 deg.

803MH/853MH Tracked Harvesters

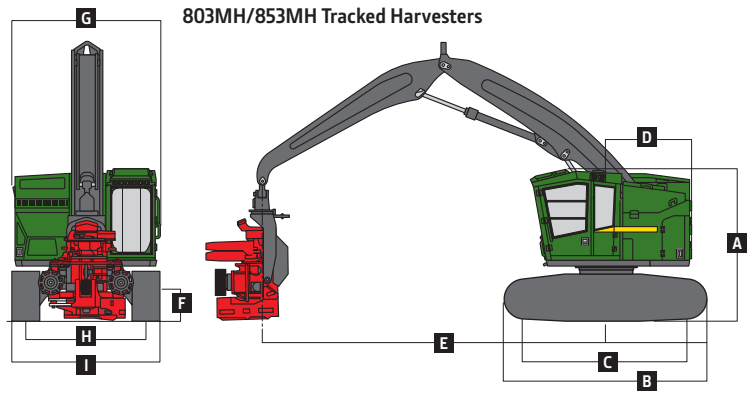

859MH Tracked Harvester

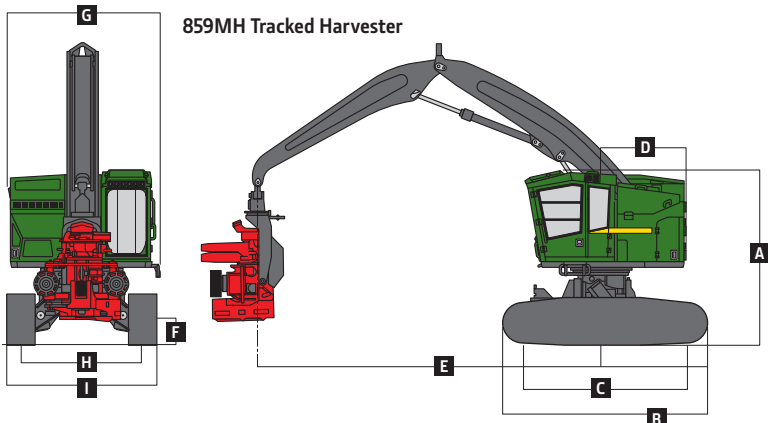



JOHN DEERE

JohnDeere.com/forestry

TO FIND SUCCESS IN THE FOREST, YOU CAN WAIT FOR THE PERFECT SET OF CONDITIONS.

Or give yourself every advantage to create your own.
Productive machines. Innovative technology. Useful insights.
Dependable support. A full set of solutions that only one
partner can provide.

The obstacles to success are many. John Deere helps you

OUTRUN™ THEM ALL.



10-01-18