

524K-II/544K-II/ 624K-II LOADERS

106–141 kW (142–188 net hp)



JOHN DEERE





Powerful. And proven.

Got a material-handling app that demands extra agility and ability? There's a John Deere K Series-II Loader for that. Built on the highly reliable platform of their predecessors, these models are loaded with even more customer-inspired productivity- and uptime-increasing features. John Deere PowerTech™ EPA Tier 3/EU Stage IIIA and Tier 2/Stage II diesels provide generous displacement, power, and lugging ability. Daily checks and maintenance access are even easier. And all new K Series-II Loaders come with a standard five-speed transmission and a new adaptive clutch cutoff that will help improve productivity compared to previous K-Series models. Get more in a K Series-II.



K-Series Specifications	524K-II	544K-II	624K-II
Net Peak Power	106 kW (142 hp)	122 kW (163 hp)	141 kW (188 hp)
Bucket Capacity	1.9–2.1 m ³ (2.5–2.75 cu. yd.)	2.3 m ³ (3.0 cu. yd.)	2.7 m ³ (3.5 cu. yd.)
Z-Bar: Tipping Load (40-deg. full turn, no tire deflection, with pin-on bucket)	9411 kg (20,748 lb.)	9619 kg (21,206 lb.)	12 006 kg (26,470 lb.)
Breakout Force	9638 kg (21,248 lb.)	10 115 kg (22,300 lb.)	12 821 kg (28,266 lb.)
Operating Weight	12 622 kg (27,827 lb.)	13 121 kg (28,927 lb.)	15 614 kg (34,423 lb.)

Easy rider.

Long days seem shorter when you're getting things done. And what operator wouldn't be more productive in the high-back air-ride seat of a K Series-II Loader? Up-front, an enhanced multifunction monitor displays operating, diagnostic, and maintenance info on a color LCD screen with easy-on-the-eyes clarity. Generous tinted glass and a low-profile console allow a commanding view of the work ahead. Spacious and quiet cab boasts plenty of legroom and fatigue-beating ergonomics, including convenience features such as seat-mounted loader controls. And sealed-switch module (SSM) with keyless start and effortless push-button operation of numerous machine functions. So you can work harder with less effort.

Adjustable automotive-style louvers provide effective airflow to keep the glass clear and the pressurized cab comfortable.

Cushioning deluxe fabric-covered seat with backrest extension features full adjustment, lumbar support, and air suspension with full-damping capability.

To help prevent unauthorized machine operation, the keyless-start security system requires a numeric pass code (when activated).



Multi-language color LCD monitor provides push-button access to a wealth of machine data and functions:

- A. Vital and general operating info**, including transmission mode, gear, engine rpm, ground speed, fuel level, and fluid temps.
- B. Enhanced onboard diagnostics** with speed, pressure, and temperature readings and real-time switch status.
- C. Customized machine settings** such as Quick Shift, Auto-to-1st, and optional Ride Control let you match operating characteristics to specific jobs and conditions.





1. Cooler compartment and beverage holder make it handy to stow your lunch.

2. Optional rearview camera and radar object-detection system or rearview camera only displays the activity behind the machine on the LCD screen. Emits an audible alert for extra awareness in tight quarters and high-traffic areas.

3. Backlit touchpad in the SSM controls keyless start and 24 other machine functions, allowing the operator to activate boom-height kick-out, return-to-carry, and return-to-dig from the seat.



Control your productivity.

If you want maximum productivity, a K Series-II Loader should be on your jobsite. It's not just their big torque reserves that make them such impressive performers. Single-lever joystick or two-lever fingertip controls provide smooth effortless control. Excavator-style hydraulics sense the load and deliver the flow needed for smooth combined functions and fast work cycles. PowerShift™ torque-converter transmission on the 524K-II employs smart shift technology to continuously evaluate speed and load conditions, and adjusts clutch-pack engagement to suit. 544K-II and 624K-II feature standard five-speed transmission with lockup torque converter in gears 2–5, to increase acceleration, speed cycles, and optimize power and fuel efficiency during transport, roading, and ramp climbing. You won't find a smoother-shifting loader.

Boom-height kick-out and return-to-carry functions help speed production in repetitive loading applications.

Engine/hydraulic match maintains good boom and bucket power into and out of the pile, for big loads, even in wet or packed materials.

Responsive steering and full 80-deg. articulation increase maneuverability in tight quarters, for faster cycle times and fewer three-point turns.

Optional wheel-spin control boosts productivity by improving traction in troublesome material or underfoot conditions. Reduces tire wear, fuel costs, and operator fatigue, too.





1. Choose single-lever joystick or two-lever fingertip pilot-operated hydraulic controls. Joystick F-N-R selector provides convenient direction and full-range gear changes. Both include innovative Quick-Shift feature for push-button gear changes, one gear at a time.
2. Hinged panel tilts away for quick ground-level access to the fuel tank, making refills convenient and easy.
3. New adaptive clutch cutoff automatically provides more power to the hydraulic system, ensures smooth control at high engine rpms and low speeds, and allows for better machine handling in all terrain without the operator having to change settings.

Designed to hit deadlines — and new heights.

K Series-II Loaders come equipped with plenty of production-boosting features to help you handle almost anything you throw their way. But if yours isn't just any application, we've got you covered with a wide variety of factory- or dealer-installed options. So you can equip your loader with exactly what you need to maximize your efforts and expand your opportunities. Not all options are available on all loaders, so see your dealer for specific details.

1. With optional ride control, the lift cylinders act as shock absorbers, cushioning bumps to enable quick and easy navigation over rough ground without losing the load. Auto-actuation travel speed is adjustable from 1.5 to 24.0 km/h (1.0 to 15.0 mph) in increments of 0.5 units.
2. General-purpose or excavating buckets are available in pin-on or coupler configurations from 1.9–2.7 m³ (2.5–3.5 cu. yd.).



Full-tire front and rear fenders and flaps help keep the machine free of mud and debris.

Two side-mounted mirrors enable additional visibility to the jobsite outside the machine.



Opt for forks with 1.52-m (60 in.) tines for versatility in handling a variety of material-moving tasks.

Self-cleaning steps and convenient hand-rails provide right-side access to the skid-resistant platform for cleaning windows.

Optional corrosion package shields electrical components and connections to help prevent corrosive materials from short-circuiting productivity.

Built to tackle whatever you've got.

It's all about uptime. So we gave the K Series-II plenty of resources to help you succeed. All three loaders come loaded with traditional John Deere durability features such as heavy-duty wet-sleeve diesels, Quad-Cool™, and solid-state electrical systems. Reinforced articulation joints with double-tapered roller bearings. Plus, booms and mainframes so tough they're warranted for three years or 10,000 hours. When you know how they're built, you'll run a Deere.





Auto-idle applies the brakes and automatically reduces engine speed to help conserve fuel after an operator-determined period of inactivity. Auto shutdown turns off the engine after extended idleness.

Standard starter protection limits cranking time and requires cool-down periods between attempts.

Hydraulically driven fan runs only as needed for efficient cooling. Helps conserve precious fuel, too.

Electrical-distribution center employs highly reliable circuit-board technology and solid-state switches that eliminate numerous wiring harnesses, fuses, relays, and connectors. Sealed gold-pin electrical connectors resist corrosion, for superior long-term integrity.

1. Planetary final drives are mounted inboard. Hydraulic wet-disc brakes on all models self-adjust.

2. Optional programmable fan automatically reverses at predetermined intervals, ejecting debris from the radiator and cooler cores. Or set individual cleaning cycles through the monitor.

3. Quad-Cool places the radiator, air-conditioner condenser, intercooler, and hydraulic, transmission, and axle coolers (standard on the 624K-II, optional on the 524K-II and 544K-II) in a unique boxed configuration that's isolated from engine heat, boosting efficiency and durability.

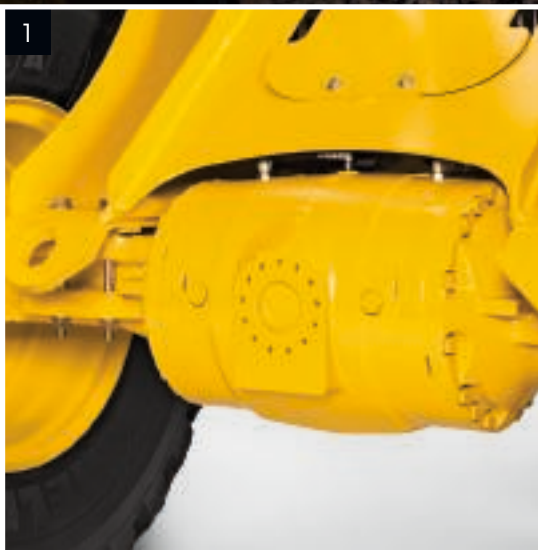

Save time — and your bottom line.

Controlling daily owning and operating costs shouldn't stretch your resources — and it doesn't on a K Series-II Loader. Same-side ground-level service points make quick work of the daily routine. Unique Quad-Cool system provides wide-open access to both sides of the coolers, easing cleanout. Extended service intervals let you work longer between changes. And because no maintenance beats low maintenance, standard self-adjusting serpentine engine belts and wet-disc brakes seldom, if ever, require attention. The list of maintenance-minimizing features — and the owning and operating savings — goes on and on.

1. Vertical spin-on filters allow quick, no-spill changes. 500-, 2,000-, and 4,000-hour engine, transmission, and hydraulic oil-change intervals help reduce operating costs.
2. Easy-to-navigate LCD monitor displays diagnostic messages if problems occur, and even offers possible solutions to help get you back up and running quickly.
3. Color-coded fluid-sample and diagnostic test ports help speed preventative maintenance and troubleshooting. Noninvasive design helps keep out contaminants.
4. Conveniently located, easy-to-read sight gauges and see-through reservoirs let you check transmission, hydraulic, coolant, and windshield washer fluid levels at a glance.
5. Master electrical-disconnect switch is enclosed in a lockable compartment beneath the right-side step, for ground-level convenience.





3-mm (0.12 in.) side-shield perforations block most airborne debris. Unlike stacked coolers, Quad-Cool cores resist plugging and are easily accessible from either side, for quick and easy cleanout.

All daily service points including fuel are conveniently grouped on the left side of the machine.

Greasing is less messy, with centralized lube banks providing easy access to difficult-to-reach zerks. Periodic lube and maintenance chart conveniently confirms that nothing gets overlooked.

John Deere WorkSight™ is an exclusive suite of telematics solutions that increases uptime while lowering operating costs. At its heart, JDLink™ Ultimate machine monitoring provides real-time utilization data and alerts to help you maximize productivity and efficiency while minimizing downtime. Remote diagnostics enable your dealer to read codes and record performance data without a trip to the jobsite.

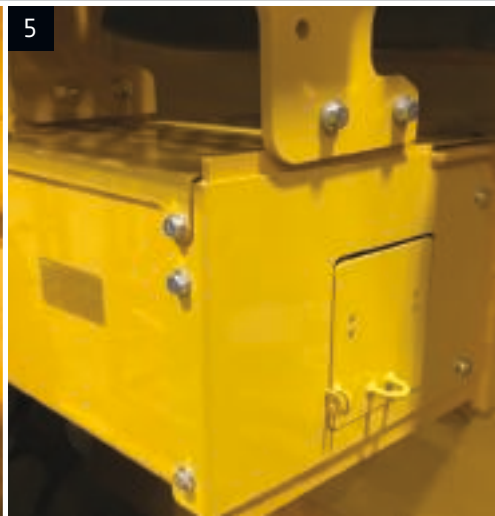

524K-II

While general information, pictures, and descriptions are provided, some illustrations and text may include product options and accessories NOT AVAILABLE in all regions, and in some countries products and accessories may require modifications or additions to ensure compliance with the local regulations of those countries.

Engine		
524K-II Z-BAR / HIGH-LIFT		
Manufacturer and Model	John Deere PowerTech™ E 6068H	John Deere PowerTech™ Plus 6068H
Non-Road Emission Standard	EPA Tier 3/EU Stage IIIA and Brazil MAR-I emissions	EPA Tier 3/EU Stage IIIA and Brazil MAR-I emissions
Cylinders	6	6
Valves per Cylinder	2	4
Displacement	6.8 L (414 cu. in.)	6.8 L (414 cu. in.)
Peak Power (ISO 9249)		
Net	106 kW (142 hp) at 1,900 rpm	106 kW (142 hp) at 1,900 rpm
Gross	112 kW (150 hp) at 2,000 rpm	112 kW (150 hp) at 2,000 rpm
Peak Torque (ISO 9249)		
Net	644 Nm (475 lb.-ft.) at 1,300 rpm	645 Nm (476 lb.-ft.) at 1,100 rpm
Gross	670 Nm (494 lb.-ft.) at 1,400 rpm	670 Nm (494 lb.-ft.) at 1,700 rpm
Net Torque Rise	43%	64%
Fuel System (electronically controlled)	High-pressure common rail	High-pressure common rail
Lubrication	Full-flow spin-on filter and integral cooler	Full-flow spin-on filter and integral cooler
Aspiration	Turbocharged, charge air cooled	Turbocharged, charge air cooled
Air Cleaner	Under-hood dual-element dry type, restriction indicator in cab monitor for service	
Cooling		
Fan Drive	Hydraulically driven, proportionally controlled, fan aft of coolers	
Electrical		
Electrical System	24 volt with 80-amp alternator (optional 100-amp alternator)	
Batteries (2 – 12 volt)	750 CCA (each)	
Lights	Driving lights with guard, turn signals, and flashers; stop- and taillight; work lights: front (4) and rear (2)	
Transmission System		
Type	Countershaft-type PowerShift™	
Torque Converter	Single stage, single phase	
Shift Control	Electronically modulated, adaptive, load and speed dependent	
Operator Interface	Steering-column or joystick-mounted F-N-R and gear-select lever; Quick-Shift button on hydraulic lever	
Shift Modes	Manual/auto (1st-D or 2nd-D); Quick-Shift button with 2 selectable modes: kick-down or kick-up/down; and adaptive clutch cutoff	
Maximum Travel Speeds (with 20.5 R 25 tires)		
	<i>Forward</i>	<i>Reverse</i>
Gear 1	5.5 km/h (3.4 mph)	5.8 km/h (3.6 mph)
Gear 2	11.7 km/h (7.3 mph)	12.3 km/h (7.6 mph)
Gear 3	17.9 km/h (11.1 mph)	27.6 km/h (17.1 mph)
Gear 4	25.8 km/h (16.0 mph)	N/A
Gear 5	38.5 km/h (23.9 mph)	N/A
Axles/Brakes		
Final Drives	Heavy-duty inboard-mounted planetary	
Differentials	Conventional non-locking rear and front – standard; hydraulic locking front with rear conventional – optional; dual locking front and rear – optional	
Rear Axle Oscillation, Stop to Stop (with 20.5 R 25 tires)	24 deg. (12 deg. each direction)	
Brakes (conform to ISO 3450)		
Service	Hydraulically actuated, inboard sun-shaft mounted, single disc; oil cooled – optional	
Parking	Automatic spring applied, hydraulically released, driveline mounted, sealed wet multi disc	
Tires/Wheels (see page 16 for complete tire adjustments)		
	<i>Tread Width</i>	<i>Width Over Tires</i>
Michelin 20.5 R 25, 1 Star L-3	1950 mm (76.8 in.)	2574 mm (101.3 in.)
Serviceability		
Refill Capacities		
Fuel Tank with Lockable Cap	220 L (58 gal.)	
Cooling System	22.5 L (23.8 qt.)	
Engine Oil with Vertical Spin-On Filter	19 L (20 qt.)	
Transmission Reservoir with Vertical Filter	21.5 L (22.7 qt.)	
Axle Oil (front and rear, each)	18 L (19 qt.)	
Hydraulic Reservoir and Filter	92 L (24.3 gal.)	
Park Brake Oil (wet disc)	0.3 L (10 oz.)	
Hydraulic System/Steering		
Pump (loader and steering)	Variable-displacement, axial-piston pump; closed-center, pressure-compensating system	
Maximum Rated Flow at 6895 kPa (1,000 psi) and 2,200 rpm	177 L/m (47 gpm)	
System Relief Pressure (loader and steering)	24 994 kPa (3,625 psi)	
Loader Controls	2-function valve, joystick control or fingertip controls, hydraulic-function enable/disable, optional 3rd- and 4th-function valve with auxiliary lever	
Steering (conforms to ISO 5010)	Steering-column-mounted, twist-grip shift lever; Quick-Shift button on hydraulic lever	
Type	Power, fully hydraulic	
Articulation Angle	80-deg. arc (40-deg. each direction)	

524K-II

While general information, pictures, and descriptions are provided, some illustrations and text may include product options and accessories NOT AVAILABLE in all regions, and in some countries products and accessories may require modifications or additions to ensure compliance with the local regulations of those countries.

Hydraulic System/Steering (continued) 524K-II Z-BAR / HIGH-LIFT

Turning Radius (measured to centerline of outside tire)	5.00 m (16 ft. 5 in.)
Hydraulic Cycle Times	
Raise	6.1 sec.
Dump	1.4 sec.
Lower (float down)	3.0 sec.
Total	10.5 sec.

Dimensions and Specifications with Pin-On Bucket

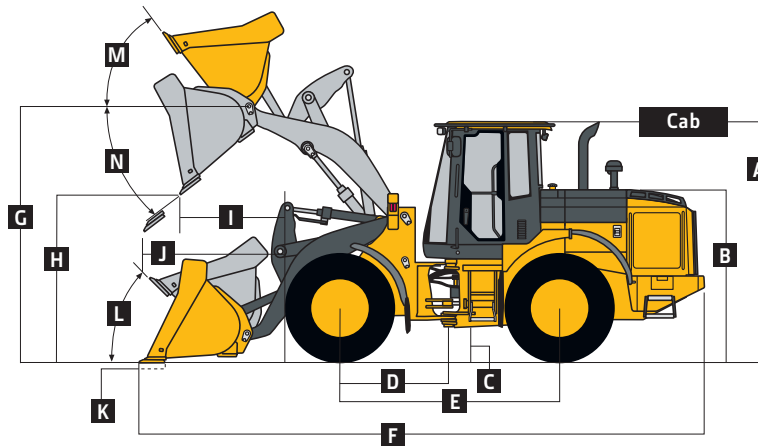

524K-II Z-BAR AND HIGH-LIFT LOADERS WITH PIN-ON BUCKET

	Z-Bar	Z-Bar	High-Lift	High-Lift
Dimensions with Bucket	1.9-m ³ (2.5 cu. yd.) general-purpose with bolt-on edge	2.1-m ³ (2.75 cu. yd.) general-purpose with bolt-on edge	1.9-m ³ (2.5 cu. yd.) general-purpose with bolt-on edge	2.1-m ³ (2.75 cu. yd.) general-purpose with bolt-on edge
A Height to Top of Cab	3.25 m (10 ft. 8 in.)	3.25 m (10 ft. 8 in.)	3.25 m (10 ft. 8 in.)	3.25 m (10 ft. 8 in.)
B Hood Height	2.30 m (7 ft. 7 in.)	2.30 m (7 ft. 7 in.)	2.30 m (7 ft. 7 in.)	2.30 m (7 ft. 7 in.)
C Ground Clearance	0.40 m (15.7 in.)	0.40 m (15.7 in.)	0.40 m (15.7 in.)	0.40 m (15.7 in.)
D Length from Centerline to Front Axle	1.45 m (4 ft. 9 in.)	1.45 m (4 ft. 9 in.)	1.45 m (4 ft. 9 in.)	1.45 m (4 ft. 9 in.)
E Wheelbase	2.93 m (9 ft. 7 in.)	2.93 m (9 ft. 7 in.)	2.93 m (9 ft. 7 in.)	2.93 m (9 ft. 7 in.)
F Overall Length, Bucket on Ground	7.25 m (23 ft. 9 in.)	7.34 m (24 ft. 1 in.)	7.58 m (24 ft. 10 in.)	7.67 m (25 ft. 2 in.)
G Height to Hinge Pin, Fully Raised	3.77 m (12 ft. 5 in.)	3.77 m (12 ft. 5 in.)	4.12 m (13 ft. 6 in.)	4.12 m (13 ft. 6 in.)
H Dump Clearance, 45 deg., Full Height	2.77 m (9 ft. 1 in.)	2.77 m (9 ft. 1 in.)	3.16 m (10 ft. 4 in.)	3.12 m (10 ft. 3 in.)
I Reach, 45-deg. Dump, Full Height	0.81 m (32 in.)	0.98 m (3 ft. 2 in.)	0.90 m (4 ft. 0 in.)	0.99 m (3 ft. 3 in.)
J Reach, 45-deg. Dump, 2.13-m (7 ft. 0 in.) Clearance	1.41 m (4 ft. 7 in.)	1.44 m (4 ft. 9 in.)	1.70 m (5 ft. 7 in.)	1.73 m (5 ft. 8 in.)
K Maximum Digging Depth	78 mm (3.1 in.)	97 mm (3.8 in.)	160 mm (6.3 in.)	222 mm (8.7 in.)
L Maximum Rollback at Ground Level	41 deg.	41 deg.	41 deg.	41 deg.
M Maximum Rollback, Boom Fully Raised	55 deg.	55 deg.	50 deg.	50 deg.
N Maximum Bucket Dump Angle, Fully Raised	51 deg.	51 deg.	47 deg.	47 deg.
Loader Clearance Circle, Bucket Carry Position	11.50 m (37 ft. 8 in.)	11.60 m (38 ft. 1 in.)	11.80 m (38 ft. 8 in.)	11.90 m (39 ft. 1 in.)
Specifications with Bucket				
Capacity, Heaped	1.9 m ³ (2.5 cu. yd.)	2.1 m ³ (2.75 cu. yd.)	1.9 m ³ (2.5 cu. yd.)	2.1 m ³ (2.75 cu. yd.)
Capacity, Struck	1.5 m ³ (2.0 cu. yd.)	1.7 m ³ (2.27 cu. yd.)	1.5 m ³ (2.0 cu. yd.)	1.7 m ³ (2.27 cu. yd.)
Bucket Weight with Bolt-On Cutting Edge	968 kg (2,134 lb.)	1013 kg (2,233 lb.)	968 kg (2,134 lb.)	1013 kg (2,233 lb.)
Bucket Width	2.54 m (8 ft. 4 in.)	2.54 m (8 ft. 4 in.)	2.54 m (8 ft. 4 in.)	2.54 m (8 ft. 4 in.)
Breakout Force	9638 kg (21,248 lb.)	9060 kg (19,974 lb.)	8922 kg (19,670 lb.)	8371 kg (18,455 lb.)
Tipping Load, Straight, No Tire Deflection	10 828 kg (23,872 lb.)	10 688 kg (23,563 lb.)	9240 kg (20,371 lb.)	9111 kg (20,086 lb.)
Tipping Load, Straight, with Tire Deflection	10 296 kg (22,699 lb.)	10 158 kg (22,394 lb.)	8841 kg (19,491 lb.)	8709 kg (19,200 lb.)
Tipping Load, 40-deg. Full Turn, No Tire Deflection	9411 kg (20,748 lb.)	9281 kg (20,461 lb.)	8007 kg (17,652 lb.)	7887 kg (17,388 lb.)
Tipping Load, 40-deg. Full Turn, with Tire Deflection	8739 kg (19,266 lb.)	8607 kg (18,975 lb.)	7479 kg (16,488 lb.)	7365 kg (16,237 lb.)
Rated Operating Load, 50% Full-Turn Tipping Load, No Tire Deflection (conforms to ISO 14397-1)*	4706 kg (10,374 lb.)	4640 kg (10,229 lb.)	4003 kg (8,826 lb.)	3943 kg (8,693 lb.)
Rated Operating Load, 50% Full-Turn Tipping Load, with Tire Deflection (conforms to ISO 14397-1)*	4369 kg (9,633 lb.)	4303 kg (9,486 lb.)	3739 kg (8,244 lb.)	3682 kg (8,117 lb.)
Operating Weight	12 622 kg (27,827 lb.)	12 667 kg (27,926 lb.)	12 792 kg (28,201 lb.)	12 837 kg (28,300 lb.)

Loader operating information is based on machine with identified linkage and standard equipment, PowerTech E 6068H (EPA Tier 3/EU Stage IIIA and Brazil MAR-I emissions) engine, ROPS cab, rear cast bumper/counterweight, transmission side-frame guards, bottom guards, standard tires, full fuel tank, and 79-kg (175 lb.) operator. This information is affected by changes in tires, ballast, and different attachments, and assumes no tire deflection per the standard ISO 14397-1 section 5.

*Rated operating capacity based on Deere attachments only.

**Adjustments to Operating Weights and Tipping Loads
with Buckets**

524K-II Z-BAR / HIGH-LIFT

Adjustments to operating weights, tipping loads, and tires are based on Z-Bar machine with pin-on 2.1-m³ (2.75 cu. yd.) general-purpose bucket with bolt-on cutting edge, ROPS cab, rear cast bumper/counterweight, transmission side-frame guards, bottom guards, standard tires, full fuel tank, and 79-kg (175 lb.) operator*

Add (+) or deduct (-) kg (lb.) as indicated for loaders with 3-piece rims	<i>Operating Weight</i>	<i>Tipping Load, Straight</i>	<i>Tipping Load, 40-deg. Full Turn</i>	<i>Tread Width</i>	<i>Width Over Tires</i>	<i>Vertical Height</i>
John Deere PowerTech E 6068H	0 kg (0 lb.)	0 kg (0 lb.)	0 kg (0 lb.)	N/A	N/A	N/A
John Deere PowerTech Plus 6068H	28 kg (90 lb.)	90 kg (198 lb.)	73 kg (162 lb.)	N/A	N/A	N/A
Michelin 20.5 R 25, 1 Star L-3	0 kg (0 lb.)	0 kg (0 lb.)	0 kg (0 lb.)	0 mm (0 in.)	0 mm (0 in.)	0 mm (0 in.)
Bridgestone 20.5 R 25, 1 Star L-3	+44 kg (+97 lb.)	+32 kg (+70 lb.)	+28 kg (+62 lb.)	0 mm (0 in.)	-5 mm (-0.2 in.)	-5 mm (-0.2 in.)
Titan 20.5-25, 16 PR L-2	-256 kg (-564 lb.)	-187 kg (-412 lb.)	-165 kg (-368 lb.)	0 mm (0 in.)	-2 mm (-0.1 in.)	+3 mm (+0.1 in.)
Firestone 20.5-25, 16 PR L-2	-276 kg (-608 lb.)	-201 kg (-443 lb.)	-178 kg (-392 lb.)	0 mm (0 in.)	-2 mm (-0.1 in.)	+3 mm (+0.1 in.)
Firestone 20.5-25, 16 PR L-3	-296 kg (-652 lb.)	-216 kg (-476 lb.)	-190 kg (-419 lb.)	0 mm (0 in.)	-2 mm (-0.1 in.)	+9 mm (+0.4 in.)
Pirelli 17.5-25 16 PR L-3	-476 kg (-1,049 lb.)	-347 kg (-765 lb.)	-306 kg (-675 lb.)	0 mm (0 in.)	-78 mm (-3 in.)	-63 mm (-2.5 in.)
Titan 17.5-25 16 PR L-3	-476 kg (-1,049 lb.)	-347 kg (-765 lb.)	-306 kg (-675 lb.)	0 mm (0 in.)	-78 mm (-3 in.)	-63 mm (-2.5 in.)
Pirelli 20.5 R 25 1 Star L-3	-16 kg (-35 lb.)	-12 kg (-26 lb.)	-10 kg (-22 lb.)	0 mm (0 in.)	+32 mm (+1.3 in.)	+7 mm (+0.3 in.)
Titan 20.5-25 16 PR L-3	-296 kg (-653 lb.)	-216 kg (-476 lb.)	-190 kg (-419 lb.)	0 mm (0 in.)	+2 mm (+0.08 in.)	+7 mm (+0.3 in.)
Michelin 20.5 R 25 XLDN L-3	-16 kg (-35 lb.)	-12 kg (-26 lb.)	-10 kg (-22 lb.)	0 mm (0 in.)	-8 mm (-0.3 in.)	-3 mm (-0.1 in.)
Michelin 17.5 R 25 G3 XHA	-348 kg (-767 lb.)	-254 kg (-560 lb.)	-224 kg (-494 lb.)	0 mm (0 in.)	-78 mm (-3 in.)	-73 mm (-2.8 in.)
CaCl ₂ in 20.5-25, L-3 Rear Tires, 75% Fill	+825 kg (+1,820 lb.)	+1010 kg (+2,227 lb.)	+891 kg (+1,964 lb.)	N/A	N/A	N/A

*May change based on vehicle configuration, weight, or tire-pressure adjustments.

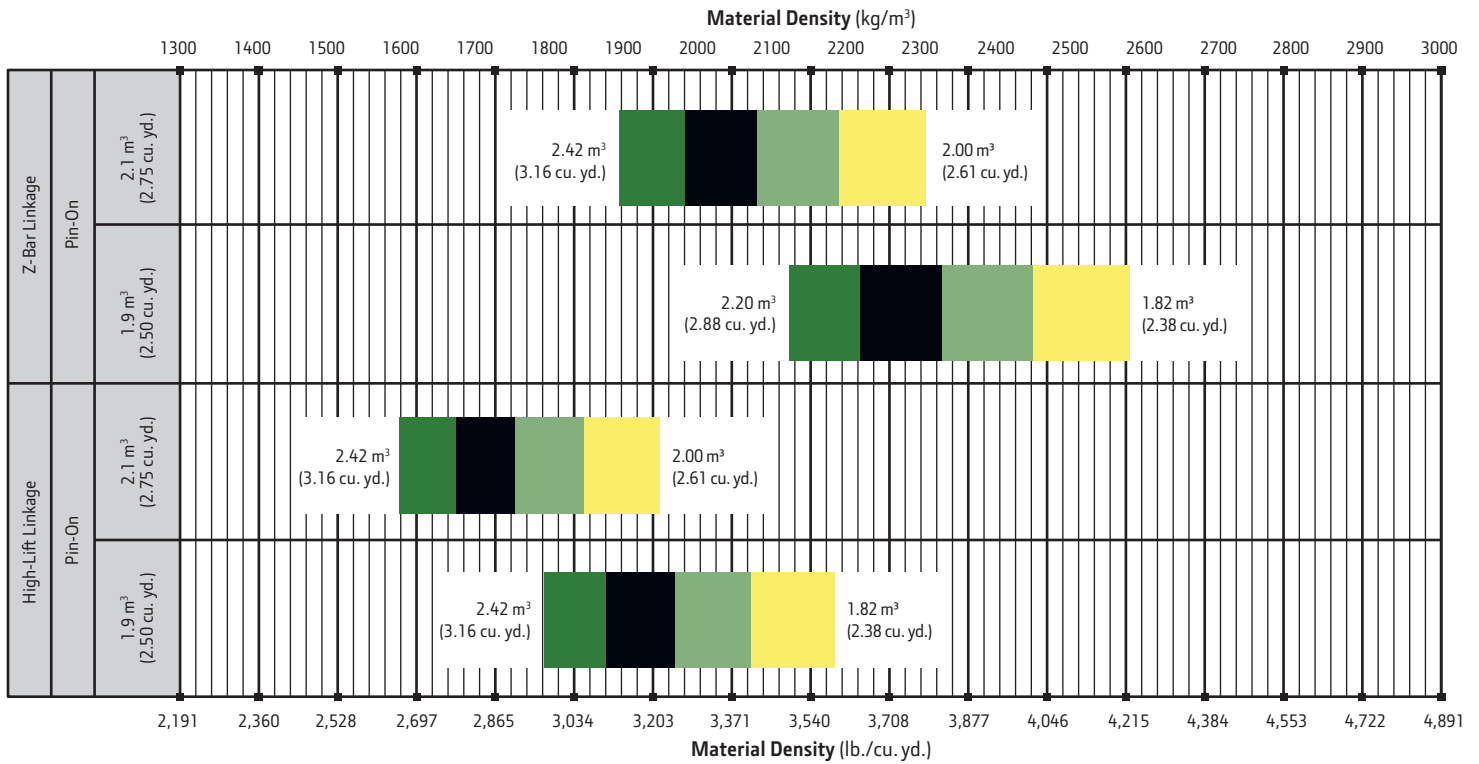

LOOSE MATERIALS	kg/m³	lb./cu. yd.	LOOSE MATERIALS	kg/m³	lb./cu. yd.
Chips, pulpwood	288	486	Limestone, coarse, sized	1570	2,646
Cinders (coal, ashes, clinkers)	673	1,134	Limestone, mixed sizes	1682	2,835
Clay and gravel, dry	1602	2,700	Limestone, pulverized or crushed	1362	2,295
Clay, compact, solid	1746	2,943	Sand, damp	2083	3,510
Clay, dry in lump loose	1009	1,701	Sand, dry	1762	2,970
Clay, excavated in water	1282	2,160	Sand, voids, full of water	2083	3,510
Coal, anthracite, broken, loose	865	1,458	Sandstone, quarried	1314	2,214
Coal, bituminous, moderately wet	801	1,350	Shale, broken crushed	1362	2,295
Earth, common loam, dry	1218	2,052	Slag, furnace granulated	1955	3,294
Earth, mud, packed	1843	3,105	Stone or gravel, 37.5 to 87.5-mm (1.5 to 3.5") size	1442	2,430
Granite, broken	1538	2,592	Stone or gravel, 18.75-mm (3/4") size	1602	2,700
Gypsum	2275	3,834			

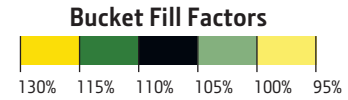

While general information, pictures, and descriptions are provided, some illustrations and text may include product options and accessories NOT AVAILABLE in all regions, and in some countries products and accessories may require modifications or additions to ensure compliance with the local regulations of those countries.

544K-II

While general information, pictures, and descriptions are provided, some illustrations and text may include product options and accessories NOT AVAILABLE in all regions, and in some countries products and accessories may require modifications or additions to ensure compliance with the local regulations of those countries.

Engine		544K-II Z-BAR / HIGH-LIFT	
Manufacturer and Model	John Deere PowerTech™ E 6068H	John Deere PowerTech™ Plus 6068H	
Non-Road Emission Standard	EPA Tier 3/EU Stage IIIA and Brazil MAR-I emissions	EPA Tier 3/EU Stage IIIA and Brazil MAR-I emissions	
Cylinders	6	6	
Valves per Cylinder	2	4	
Displacement	6.8 L (414 cu. in.)	6.8 L (414 cu. in.)	
Peak Power (ISO 9249)			
Net	122 kW (163 hp) at 1,900 rpm	122 kW (163 hp) at 1,800 rpm	
Gross	128 kW (172 hp) at 1,900 rpm	128 kW (172 hp) at 1,900 rpm	
Peak Torque (ISO 9249)			
Net	659 Nm (486 lb.-ft.) at 1,600 rpm	683 Nm (504 lb.-ft.) at 1,100 rpm	
Gross	687 Nm (507 lb.-ft.) at 1,600 rpm	713 Nm (526 lb.-ft.) at 1,700 rpm	
Net Torque Rise	39%	45%	
Fuel System (electronically controlled)	High-pressure common rail	High-pressure common rail	
Lubrication	Full-flow spin-on filter and integral cooler	Full-flow spin-on filter and integral cooler	
Aspiration	Turbocharged, charge air cooled	Turbocharged, charge air cooled	
Air Cleaner	Under-hood, dual-element dry type, restriction indicator in cab monitor for service		
Cooling			
Fan Drive	Hydraulically driven, proportionally controlled, fan aft of coolers		
Electrical			
Electrical System	24 volt with 80-amp alternator (optional 100-amp alternator)		
Batteries (2 – 12 volt)	750 CCA (each)		
Lights	Driving lights with guard, turn signals, and flashers; stop- and taillight; work lights: front (4) and rear (2)		
Transmission System			
Type	Countershaft-type PowerShift™		
Torque Converter	Single stage, single phase		
Shift Control	Electronically modulated, adaptive, load and speed dependent		
Operator Interface	Steering-column or joystick-mounted F-N-R and gear-select lever; kick-down button on hydraulic lever		
Shift Modes	Manual/auto (1st-D or 2nd-D); Quick-Shift button with 2 selectable modes: kick-down or kick-up/down; and adaptive clutch cutoff		
	<i>Standard 5-Speed with Lockup Torque Converter [LUTC]</i>		<i>Optional 5-Speed without LUTC</i>
Maximum Travel Speeds (with 20.5 R 25 tires)	<i>Forward</i>	<i>Reverse</i>	<i>Forward</i>
Gear 1	5.8 km/h (3.6 mph)	6.3 km/h (3.9 mph)	5.2 km/h (3.2 mph)
Gear 2	12.0 km/h (7.5 mph)	12.7 km/h (7.9 mph)	10.9 km/h (6.8 mph)
Gear 3	18.6 km/h (11.6 mph)	29.1 km/h (18.1 mph)	16.6 km/h (10.3 mph)
Gear 4	27.7 km/h (17.2 mph)	N/A	23.8 km/h (14.8 mph)
Gear 5	40.0 km/h (24.9 mph)	N/A	37.6 km/h (23.4 mph)
<i>Reverse</i>			5.5 km/h (3.4 mph)
<i>Reverse</i>			11.5 km/h (7.2 mph)
<i>Reverse</i>			25.3 km/h (15.7 mph)
<i>Reverse</i>			N/A
<i>Reverse</i>			N/A
Axles/Brakes			
Final Drives	Heavy-duty inboard-mounted planetary		
Differentials	Hydraulic locking front with conventional rear – standard; dual locking front and rear – optional		
Rear Axle Oscillation, Stop to Stop (with 20.5 R 25 tires)	24 deg. (12 deg. each direction)		
Brakes (conform to ISO 3450)			
Service	Hydraulically actuated, inboard sun-shaft mounted, single disc; oil cooled – optional		
Parking	Automatic spring applied, hydraulically released, driveline mounted, sealed wet multi disc		
Tires/Wheels (see page 20 for complete tire adjustments)			
	<i>Tread Width</i>	<i>Width Over Tires</i>	
Michelin 20.5 R 25, 1 Star L-3	1950 mm (76.8 in.)	2574 mm (101.3 in.)	
Serviceability			
Refill Capacities			
Fuel Tank with Lockable Cap	325 L (86 gal.)		
Cooling System	22.5 L (23.8 qt.)		
Engine Oil with Vertical Spin-On Filter	19 L (20 qt.)		
Transmission Reservoir with Vertical Filter	18.5 L (19.5 qt.)		
Axle Oil (front and rear, each)	17 L (18 qt.)		
Hydraulic Reservoir and Filter	92 L (24.3 gal.)		
Park Brake Oil (wet disc)	0.3 L (10 oz.)		
Hydraulic System/Steering			
Pump (loader and steering)	Variable-displacement, axial-piston pump; closed-center, pressure-compensating system		
Maximum Rated Flow at 6895 kPa (1,000 psi) and 2,200 rpm	188 L/m (50 gpm)		
System Relief Pressure (loader and steering)	25 166 kPa (3,650 psi)		
Loader Controls	2-function valve, joystick control or fingertip controls, hydraulic-function enable/disable, optional 3rd- and 4th-function valve with auxiliary lever		
Steering (conforms to ISO 5010)	Steering-column-mounted, twist-grip shift lever; Quick-Shift button on hydraulic lever		
Type	Power, fully hydraulic		
Articulation Angle	80-deg. arc (40-deg. each direction)		



While general information, pictures, and descriptions are provided, some illustrations and text may include product options and accessories NOT AVAILABLE in all regions, and in some countries products and accessories may require modifications or additions to ensure compliance with the local regulations of those countries.

Hydraulic System/Steering (continued)		544K-II Z-BAR / HIGH-LIFT
Turning Radius (measured to centerline of outside tire)		5.00 m (16 ft. 5 in.)
Hydraulic Cycle Times		
Raise		5.8 sec.
Dump		1.2 sec.
Lower (float down)		3.2 sec.
Total		10.2 sec.

Dimensions and Specifications with Pin-On Bucket

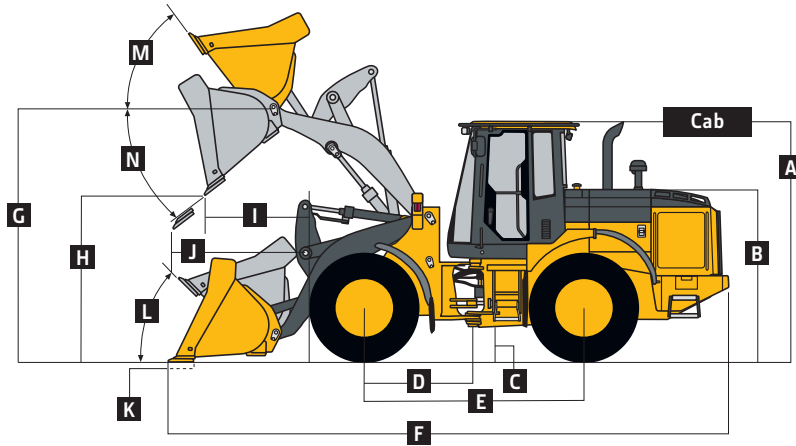

544K-II Z-BAR AND HIGH-LIFT LOADERS WITH PIN-ON BUCKET

	Z-Bar Narrow 2.3-m ³ (3.0 cu. yd.) general-purpose with bolt-on edge	High-Lift Narrow 2.3-m ³ (3.0 cu. yd.) general-purpose with bolt-on edge
Dimensions with Bucket		
A Height to Top of Cab	3.24 m (10 ft. 8 in.)	3.24 m (10 ft. 8 in.)
B Hood Height	2.30 m (7 ft. 7 in.)	2.30 m (7 ft. 7 in.)
C Ground Clearance	0.40 m (15.7 in.)	0.40 m (15.7 in.)
D Length from Centerline to Front Axle	1.45 m (4 ft. 9 in.)	1.45 m (4 ft. 9 in.)
E Wheelbase	2.93 m (9 ft. 7 in.)	2.93 m (9 ft. 7 in.)
F Overall Length, Bucket on Ground	7.43 m (24 ft. 4 in.)	7.75 m (25 ft. 5 in.)
G Height to Hinge Pin, Fully Raised	3.82 m (12 ft. 6 in.)	4.17 m (13 ft. 8 in.)
H Dump Clearance, 45 deg., Full Height	2.76 m (9 ft. 1 in.)	3.11 m (10 ft. 3 in.)
I Reach, 45-deg. Dump, Full Height	0.99 m (3 ft. 3 in.)	0.99 m (3 ft. 3 in.)
J Reach, 45-deg. Dump, 2.13-m (7 ft. 0 in.) Clearance	1.46 m (4 ft. 10 in.)	1.76 m (5 ft. 9 in.)
K Maximum Digging Depth	95 mm (3.72 in.)	221 mm (8.7 in.)
L Maximum Rollback at Ground Level	42 deg.	37 deg.
M Maximum Rollback, Boom Fully Raised	55 deg.	50 deg.
N Maximum Bucket Dump Angle, Fully Raised	49 deg.	46 deg.
Loader Clearance Circle, Bucket Carry Position	11.65 m (38 ft. 3 in.)	11.96 m (39 ft. 3 in.)
Specifications with Bucket		
Capacity, Heaped	2.3 m ³ (3.0 cu. yd.)	2.3 m ³ (3.0 cu. yd.)
Capacity, Struck	2.0 m ³ (2.6 cu. yd.)	2.0 m ³ (2.6 cu. yd.)
Bucket Weight with Bolt-On Cutting Edge	1066 kg (2,350 lb.)	1066 kg (2,350 lb.)
Bucket Width	2.54 m (8 ft. 4 in.)	2.54 m (8 ft. 4 in.)
Breakout Force	10 115 kg (22,300 lb.)	9351 kg (20,615 lb.)
Tipping Load, Straight, No Tire Deflection	11 103 kg (24,478 lb.)	9528 kg (21,006 lb.)
Tipping Load, Straight, with Tire Deflection	10 533 kg (23,221 lb.)	9090 kg (20,040 lb.)
Tipping Load, 40-deg. Full Turn, No Tire Deflection	9619 kg (21,206 lb.)	8228 kg (18,140 lb.)
Tipping Load, 40-deg. Full Turn, with Tire Deflection	8883 kg (19,584 lb.)	7656 kg (16,878 lb.)
Rated Operating Load, 50% Full-Turn Tipping Load, No Tire Deflection (conforms to ISO 14397-1)*	4809 kg (10,602 lb.)	4114 kg (9070 lb.)
Rated Operating Load, 50% Full-Turn Tipping Load, with Tire Deflection (conforms to ISO 14397-1)*	4441 kg (9,791 lb.)	3828 kg (8439 lb.)
Operating Weight	13 121 kg (28,927 lb.)	13 240 kg (29,189 lb.)

Loader operating information is based on machine with identified linkage and standard equipment, PowerTech E 6068H (EPA Tier 3/EU Stage IIIA and Brazil MAR-I emissions) engine, ROPS cab, rear cast bumper/counterweight, transmission side-frame guards, bottom guards, standard tires, full fuel tank, and 79-kg (175 lb.) operator. This information is affected by changes in tires, ballast, and different attachments, and assumes no tire deflection per the standard ISO 14397-1 section 5.

*Rated operating capacity based on Deere attachments only.

**Adjustments to Operating Weights and Tipping Loads
with Buckets**

544K-II Z-BAR / HIGH-LIFT

Adjustments to operating weights, tipping loads, and tires are based on Z-Bar machine with pin-on 2.3-m³ (3.0 cu. yd.) general-purpose bucket with bolt-on cutting edge, ROPS cab, rear cast bumper/counterweight, transmission side-frame guards, bottom guards, standard tires, full fuel tank, and 79-kg (175 lb.) operator*

Add (+) or deduct (-) kg (lb.) as indicated for loaders with 3-piece rims	Operating Weight	Tipping Load, Straight	Tipping Load, 40-deg. Full Turn	Tread Width	Width Over Tires	Vertical Height
John Deere PowerTech E 6068H	0 kg (0 lb.)	0 kg (0 lb.)	0 kg (0 lb.)	N/A	N/A	N/A
John Deere PowerTech Plus 6068H	28 kg (90 lb.)	90 kg (198 lb.)	73 kg (162 lb.)	N/A	N/A	N/A
Michelin 20.5 R 25, 1 Star L-3	0 kg (0 lb.)	0 kg (0 lb.)	0 kg (0 lb.)	0 mm (0 in.)	0 mm (0 in.)	0 mm (0 in.)
Bridgestone 20.5 R 25, 1 Star L-3	+44 kg (+97 lb.)	+32 kg (+71 lb.)	+28 kg (+62 lb.)	0 mm (0 in.)	-5 mm (-0.2 in.)	-5 mm (-0.2 in.)
Titan 20.5-25, 16 PR L-2	-256 kg (-564 lb.)	-186 kg (-410 lb.)	-164 kg (-362 lb.)	0 mm (0 in.)	-2 mm (-0.1 in.)	+3 mm (+0.1 in.)
Firestone 20.5-25, 16 PR L-2	-276 kg (-608 lb.)	-201 kg (-443 lb.)	-180 kg (-397 lb.)	0 mm (0 in.)	-2 mm (-0.1 in.)	+3 mm (+0.1 in.)
Firestone 20.5-25, 16 PR L-3	-296 kg (-653 lb.)	-215 kg (-474 lb.)	-190 kg (-419 lb.)	0 mm (0 in.)	-2 mm (-0.1 in.)	+9 mm (+0.4 in.)
Pirelli 20.5 R 25 1 Star L-3	-16 kg (-35 lb.)	-12 kg (-26 lb.)	-10 kg (-22 lb.)	0 mm (0 in.)	+2 mm (+0.1 in.)	+7 mm (+0.3 in.)
Titan 20.5-25 16 PR L-3	-296 kg (-653 lb.)	-215 kg (-474 lb.)	-190 kg (-419 lb.)	0 mm (0 in.)	+2 mm (+0.1 in.)	+7 mm (+0.3 in.)
Michelin 20.5 R 25 XLDN L-3	-16 kg (-35 lb.)	-12 kg (-26 lb.)	-10 kg (-22 lb.)	0 mm (0 in.)	+2 mm (+0.1 in.)	-3 mm (-0.11 in.)
CaCl ₂ in 20.5-25, L-3 Rear Tires, 75% Fill	+825 kg (+1,820 lb.)	+1010 kg (+2,227 lb.)	+891 kg (+1,964 lb.)	N/A	N/A	N/A

*May change based on vehicle configuration, weight, or tire-pressure adjustments.

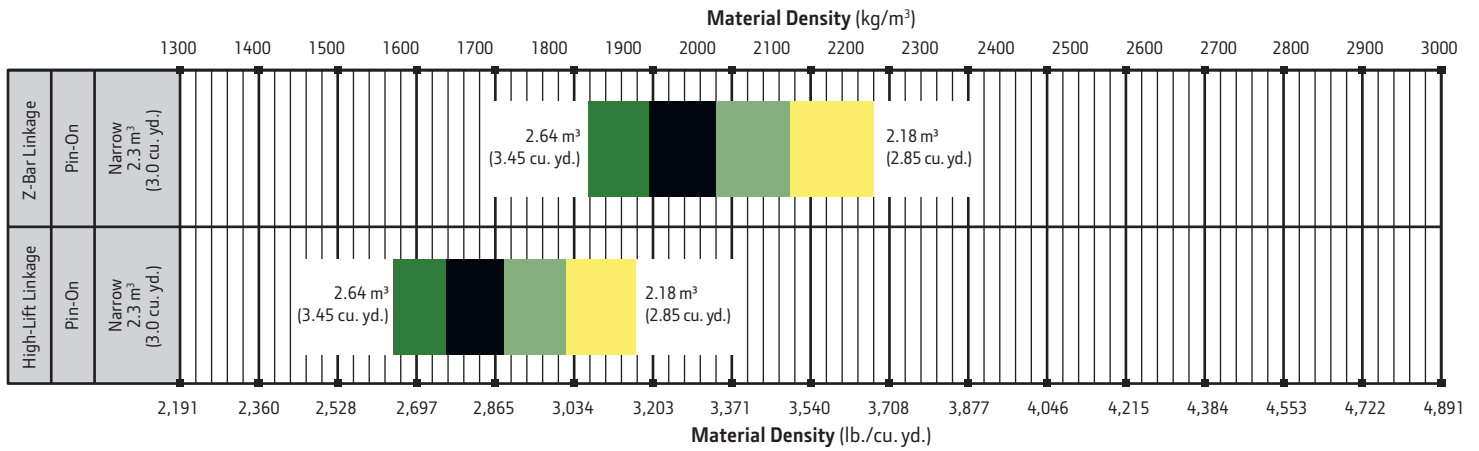

LOOSE MATERIALS	kg/m³	lb./cu. yd.	LOOSE MATERIALS	kg/m³	lb./cu. yd.
Chips, pulpwood	288	486	Limestone, coarse, sized	1570	2,646
Cinders (coal, ashes, clinkers)	673	1,134	Limestone, mixed sizes	1682	2,835
Clay and gravel, dry	1602	2,700	Limestone, pulverized or crushed	1362	2,295
Clay, compact, solid	1746	2,943	Sand, damp	2083	3,510
Clay, dry in lump loose	1009	1,701	Sand, dry	1762	2,970
Clay, excavated in water	1282	2,160	Sand, voids, full of water	2083	3,510
Coal, anthracite, broken, loose	865	1,458	Sandstone, quarried	1314	2,214
Coal, bituminous, moderately wet	801	1,350	Shale, broken crushed	1362	2,295
Earth, common loam, dry	1218	2,052	Slag, furnace granulated	1955	3,294
Earth, mud, packed	1843	3,105	Stone or gravel, 37.5 to 87.5-mm (1.5 to 3.5") size	1442	2,430
Granite, broken	1538	2,592	Stone or gravel, 18.75-mm (3/4") size	1602	2,700
Gypsum	2275	3,834			

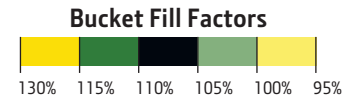

While general information, pictures, and descriptions are provided, some illustrations and text may include product options and accessories NOT AVAILABLE in all regions, and in some countries products and accessories may require modifications or additions to ensure compliance with the local regulations of those countries.

624K-II

While general information, pictures, and descriptions are provided, some illustrations and text may include product options and accessories NOT AVAILABLE in all regions, and in some countries products and accessories may require modifications or additions to ensure compliance with the local regulations of those countries.

Engine		624K-II Z-BAR / HIGH-LIFT	
Manufacturer and Model	John Deere PowerTech™ Plus 6068H	John Deere PowerTech™ 6068H	
Non-Road Emission Standard	EPA Tier 3/EU Stage IIIA and Brazil MAR-I emissions	EPA Tier 2/EU Stage II	
Cylinders	6	6	
Valves per Cylinder	4	4	
Displacement	6.8 L (414 cu. in.) standard and lockup torque converter (LUTC) transmissions		
Peak Power (ISO 9249)			
Net	141 kW (188 hp) at 1,800 rpm	141 kW (188 hp) at 1,800 rpm	
Gross	149 kW (200 hp) at 1,800 rpm	149 kW (200 hp) at 1,800 rpm	
Peak Torque (ISO 9249)			
Net	804 Nm (593 lb.-ft.) at 1,400 rpm	804 Nm (593 lb.-ft.) at 1,400 rpm	
Gross	844 Nm (623 lb.-ft.) at 1,600 rpm	844 Nm (623 lb.-ft.) at 1,600 rpm	
Net Torque Rise	57% standard transmission / 50% LUTC transmission	57% standard transmission / 50% LUTC transmission	
Fuel System (electronically controlled)	High-pressure common rail		
Lubrication	Full-flow spin-on filter and integral cooler		
Aspiration	Turbocharged, charge air cooled		
Air Cleaner	Under-hood, dual-element dry type, restriction indicator in cab monitor for service		
Cooling			
Fan Drive	Hydraulically driven, proportionally controlled, fan aft of coolers		
Electrical			
Electrical System	24 volt with 80-amp alternator (optional 100-amp alternator)		
Batteries (2 – 12 volt)	750 CCA (each)		
Lights	Driving lights with guard, turn signals, and flashers; stop- and taillight; work lights: front (4) and rear (2)		
Transmission System			
Type	Countershaft-type PowerShift™		
Torque Converter	Single stage, single phase		
Shift Control	Electronically modulated, adaptive, load and speed dependent		
Operator Interface	Steering-column or joystick-mounted F-N-R and gear-select lever; Quick-Shift button on hydraulic lever		
Shift Modes	Manual/auto (1st-D or 2nd-D); Quick-Shift button with 2 selectable modes: kick-down or kick-up/down; and adaptive clutch cutoff		
	<i>Standard 5-Speed with LUTC</i>		<i>Optional 5-Speed without LUTC</i>
Maximum Travel Speeds (with 20.5 R 25 tires)	<i>Forward</i>	<i>Reverse</i>	<i>Forward</i> <i>Reverse</i>
Gear 1	6.2 km/h (3.85 mph)	6.6 km/h (4.1 mph)	6.4 km/h (4.0 mph) 6.7 km/h (4.2 mph)
Gear 2	11.1 km/h (6.9 mph)	11.8 km/h (7.3 mph)	11.3 km/h (7.0 mph) 11.9 km/h (7.4 mph)
Gear 3	17.1 km/h (10.6 mph)	28.1 km/h (17.5 mph)	17.0 km/h (10.6 mph) 26.5 km/h (16.5 mph)
Gear 4	26.7 km/h (16.6 mph)	N/A	25.4 km/h (15.8 mph) N/A
Gear 5	40.0 km/h (24.9 mph)	N/A	36.3 km/h (22.5 mph) N/A
Axles/Brakes			
Final Drives	Heavy-duty inboard-mounted planetary		
Differentials	Hydraulic locking front with conventional rear – standard; dual locking front and rear – optional		
Rear Axle Oscillation, Stop to Stop (with 20.5 R 25 tires)	24 deg. (12 deg. each direction)		
Brakes (conform to ISO 3450)			
Service	Hydraulically actuated, spring-retracted, self-adjusting, inboard sun-shaft mounted, oil cooled, single disc		
Parking	Automatic spring applied, hydraulically released, driveline mounted, oil cooled, multi disc		
Tires/Wheels (see page 24 for complete tire adjustments)			
	<i>Tread Width</i>	<i>Width Over Tires</i>	
Michelin 20.5 R 25, 1 Star L-3	2050 mm (80.7 in.)	2670 mm (105.1 in.)	
Serviceability			
Refill Capacities			
Fuel Tank with Lockable Cap	352 L (93 gal.)		
Cooling System	27 L (29 qt.)		
Engine Oil with Vertical Spin-On Filter	19 L (20 qt.)		
Transmission Reservoir with Vertical Filter	22 L (23 qt.)		
Axle Oil			
Front	22 L (23 qt.)		
Rear	17 L (18 qt.)		
Hydraulic Reservoir and Filter	110 L (29 gal.)		
Park Brake Oil (wet disc)	0.3 L (10 oz.)		
Hydraulic System/Steering			
Pump (loader and steering)	Variable-displacement, axial-piston pump; closed-center, pressure-compensating system		
Maximum Rated Flow at 6895 kPa (1,000 psi) and 2,200 rpm	208 L/m (55 gpm)		
System Relief Pressure (loader and steering)	24 821 kPa (3,675 psi)		
Loader Controls	2-function valve, joystick control or fingertip controls, hydraulic-function enable/disable, optional 3rd- and 4th-function valve with auxiliary lever		



While general information, pictures, and descriptions are provided, some illustrations and text may include product options and accessories NOT AVAILABLE in all regions, and in some countries products and accessories may require modifications or additions to ensure compliance with the local regulations of those countries.

Hydraulic System/Steering (continued)

624K-II Z-BAR / HIGH-LIFT

Steering (conforms to ISO 5010)

Type	Power, fully hydraulic
Articulation Angle	80-deg. arc (40-deg. each direction)
Turning Radius (measured to centerline of outside tire)	5.27 m (17 ft. 4 in.)
Hydraulic Cycle Times	
Raise	5.9 sec.
Dump	1.3 sec.
Lower (float down)	2.7 sec.
Total	9.9 sec.

Dimensions and Specifications with Pin-On Bucket

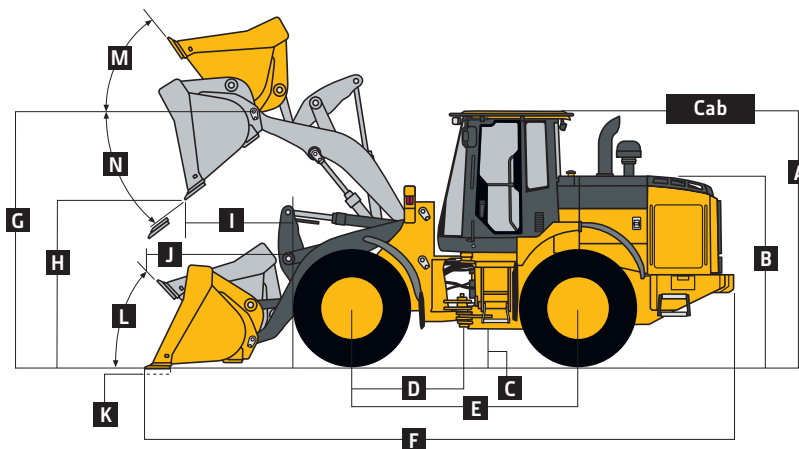

624K-II Z-BAR AND HIGH-LIFT LOADERS WITH PIN-ON BUCKET

	Z-Bar	High-Lift
Dimensions with Bucket	2.7-m ³ (3.5 cu. yd.) general-purpose with bolt-on edge	2.7-m ³ (3.5 cu. yd.) general-purpose with bolt-on edge
A Height to Top of Cab	3.32 m (10 ft. 11 in.)	3.32 m (10 ft. 11 in.)
B Hood Height	2.46 m (8 ft. 1 in.)	2.46 m (8 ft. 1 in.)
C Ground Clearance	384 mm (15.1 in.)	384 mm (15.1 in.)
D Length from Centerline to Front Axle	1.52 m (5 ft. 0 in.)	1.52 m (5 ft. 0 in.)
E Wheelbase	3.09 m (10 ft. 1 in.)	3.09 m (10 ft. 1 in.)
F Overall Length, Bucket on Ground	7.76 m (25 ft. 5 in.)	8.17 m (26 ft. 9 in.)
G Height to Hinge Pin, Fully Raised	3.95 m (13 ft. 0 in.)	4.30 m (14 ft. 2 in.)
H Dump Clearance, 45 deg., Full Height	2.86 m (9 ft. 5 in.)	3.23 m (10 ft. 7 in.)
I Reach, 45-deg. Dump, Full Height	1.02 m (3 ft. 4 in.)	1.11 m (3 ft. 8 in.)
J Reach, 45-deg. Dump, 2.13-m (7 ft. 0 in.) Clearance	1.57 m (5 ft. 2 in.)	1.93 m (6 ft. 4 in.)
K Maximum Digging Depth	95 mm (3.8 in.)	203 mm (8.0 in.)
L Maximum Rollback at Ground Level	37 deg.	36 deg.
M Maximum Rollback, Boom Fully Raised	50 deg.	49 deg.
N Maximum Bucket Dump Angle, Fully Raised	45 deg.	46 deg.
Loader Clearance Circle, Bucket Carry Position	12.24 m (40 ft. 2 in.)	12.61 m (41 ft. 4 in.)
Specifications with Bucket		
Capacity, Heaped	2.7 m ³ (3.5 cu. yd.)	2.7 m ³ (3.5 cu. yd.)
Capacity, Struck	2.3 m ³ (3.0 cu. yd.)	2.3 m ³ (3.0 cu. yd.)
Bucket Weight with Bolt-On Cutting Edge	1148 kg (2,532 lb.)	1148 kg (2,532 lb.)
Bucket Width	2.69 m (8 ft. 10 in.)	2.69 m (8 ft. 10 in.)
Breakout Force	12 821 kg (28,266 lb.)	11 662 kg (25,709 lb.)
Tipping Load, Straight, No Tire Deflection	13 849 kg (30,532 lb.)	11 628 kg (25,636 lb.)
Tipping Load, Straight, with Tire Deflection	13 158 kg (29,008 lb.)	10 836 kg (23,889 lb.)
Tipping Load, 40-deg. Full Turn, No Tire Deflection	12 006 kg (26,470 lb.)	10 044 kg (22,144 lb.)
Tipping Load, 40-deg. Full Turn, with Tire Deflection	11 043 kg (24,346 lb.)	9114 kg (20,093 lb.)
Rated Operating Load, 50% Full Turn Tipping Load, No Tire Deflection (conforms to ISO 14397-1)*	6003 kg (13,234 lb.)	5022 kg (11,072 lb.)
Rated Operating Load, 50% Full Turn Tipping Load, with Tire Deflection (Conforms to ISO 14397-1)*	5522 kg (12,173 lb.)	4557 kg (10,046 lb.)
Operating Weight	15 614 kg (34,423 lb.)	15 818 kg (34,872 lb.)

Loader operating information is based on machine with identified linkage and standard equipment, PowerTech Plus 6068H (EPA Tier 3/EU Stage IIIA and Brazil MAR-I emissions) engine, ROPS cab, rear cast bumper/counterweight, transmission side-frame guards, bottom guards, standard tires, full fuel tank, and 79-kg (175 lb.) operator. This information is affected by changes in tires, ballast, and different attachments, and assumes no tire deflection per the standard ISO 14397-1 section 5.

*Rated operating capacity based on Deere attachments only.

Adjustments to Operating Weights and Tipping

Loads with Buckets

624K-II Z-BAR / HIGH-LIFT

Adjustments to operating weights, tipping loads, and tires are based on Z-Bar machine with pin-on 2.7-m³ (3.5 cu. yd.) general-purpose bucket with bolt-on cutting edge, ROPS cab, rear cast bumper/counterweight, transmission side-frame guards, bottom guards, standard tires, full fuel tank, and 79-kg (175 lb.) operator*

Add (+) or deduct (-) kg (lb.) as indicated for loaders with 3-piece rims	Operating Weight	Tipping Load, Straight	Tipping Load, 40-deg. Full Turn	Tread Width	Width Over Tires	Vertical Height
John Deere PowerTech Plus 6068H	0 kg (0 lb.)	0 kg (0 lb.)	0 kg (0 lb.)	N/A	N/A	N/A
John Deere PowerTech 6068H	0 kg (0 lb.)	0 kg (0 lb.)	0 kg (0 lb.)	N/A	N/A	N/A
Michelin 20.5 R 25, 1 Star L-3	0 kg (0 lb.)	0 kg (0 lb.)	0 kg (0 lb.)	0 mm (0 in.)	0 mm (0 in.)	0 mm (0 in.)
Bridgestone 20.5 R 25, 1 Star L-3	+44 kg (+97 lb.)	+33 kg (+73 lb.)	+29 kg (+64 lb.)	0 mm (0 in.)	-16 mm (-0.6 in.)	0 mm (0 in.)
Firestone 20.5-25, 16 PR L-3	-252 kg (-556 lb.)	-189 kg (-417 lb.)	-167 kg (-367 lb.)	0 mm (0 in.)	-12 mm (-0.5 in.)	+13 mm (+0.5 in.)
Firestone 20.5-25, 16 PR L-2	-280 kg (-617 lb.)	-210 kg (-464 lb.)	-185 kg (-408 lb.)	0 mm (0 in.)	-12 mm (-0.5 in.)	+6 mm (+0.2 in.)
Michelin 20.5 R 25 XLDN L-3	-32 kg (-76 lb.)	-24 kg (-53 lb.)	-21 kg (-46 lb.)	0 mm (0 in.)	-16 mm (-0.6 in.)	-3 mm (-0.1 in.)
Titan 20.5-25 16 PR L-3	-204 kg (-450 lb.)	-153 kg (-337 lb.)	-135 kg (-298 lb.)	0 mm (0 in.)	-16 mm (-0.6 in.)	-3 mm (-0.1 in.)
Pirelli 20.5 R 25 1 Star L-3	-32 kg (-76 lb.)	-24 kg (-53 lb.)	-21 kg (-46 lb.)	0 mm (0 in.)	-12 mm (-0.5 in.)	+6 mm (+0.2 in.)
CaCl ₂ in 20.5-25, L-3 Rear Tires	+1166 kg (+2,571 lb.)	+1432 kg (+3,157 lb.)	+1305 kg (+2,878 lb.)	N/A	N/A	N/A

*May change based on vehicle configuration, weight, or tire-pressure adjustments.

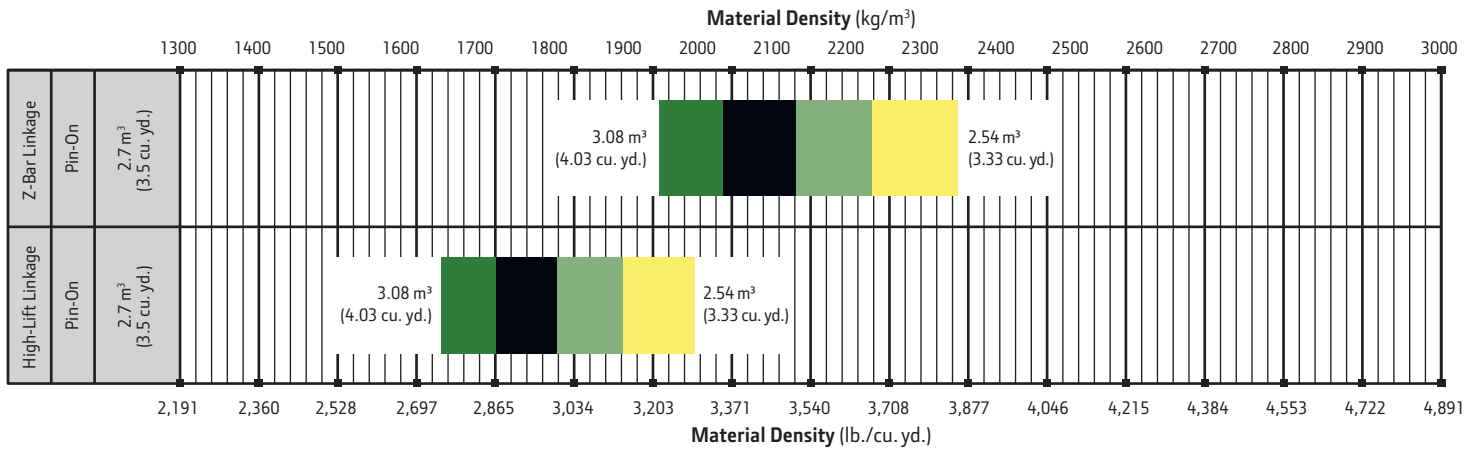

LOOSE MATERIALS	kg/m³	lb./cu. yd.	LOOSE MATERIALS	kg/m³	lb./cu. yd.
Chips, pulpwood	288	486	Limestone, coarse, sized	1570	2,646
Cinders (coal, ashes, clinkers)	673	1,134	Limestone, mixed sizes	1682	2,835
Clay and gravel, dry	1602	2,700	Limestone, pulverized or crushed	1362	2,295
Clay, compact, solid	1746	2,943	Sand, damp	2083	3,510
Clay, dry in lump loose	1009	1,701	Sand, dry	1762	2,970
Clay, excavated in water	1282	2,160	Sand, voids, full of water	2083	3,510
Coal, anthracite, broken, loose	865	1,458	Sandstone, quarried	1314	2,214
Coal, bituminous, moderately wet	801	1,350	Shale, broken crushed	1362	2,295
Earth, common loam, dry	1218	2,052	Slag, furnace granulated	1955	3,294
Earth, mud, packed	1843	3,105	Stone or gravel, 37.5 to 87.5-mm (1.5 to 3.5") size	1442	2,430
Granite, broken	1538	2,592	Stone or gravel, 18.75-mm (3/4") size	1602	2,700
Gypsum	2275	3,834			

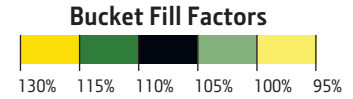

While general information, pictures, and descriptions are provided, some illustrations and text may include product options and accessories NOT AVAILABLE in all regions, and in some countries products and accessories may require modifications or additions to ensure compliance with the local regulations of those countries.

Additional equipment

Key: ● Standard ▲ Optional or special See your John Deere dealer for further information.

524	544	624	Engine
●	●	●	Wet-sleeve cylinder liners
		●	Automatic glow plugs for cold start
●	●	●	Programmable auto-idle and auto shutdown
●	●	●	Selected idle adjustment from 900–1,250 rpm
●	●	●	Starter protection
●	●	●	Automatic derating for exceeded system temperatures
●	●	●	Serpentine drive belt for automatic tensioner
●	●		Under-hood prescreened air intake
		●	Electrical fuel-priming pump
●	●	●	Dual-stage fuel filter and water separator
●	●	●	500-hour vertical spin-on oil filter
▲	▲	▲	Centrifugal engine air pre-cleaner
▲	▲	▲	Chrome exhaust stack
▲	▲		Automatic ether starting aid (recommended for cold starts below –12 deg. C [10 deg. F])
			Powertrain
●	●	●	Axle oil temperature sensing
●	●	●	Programmable maximum high gear
●	●	●	Clutch calibration engaged from monitor
●	●	●	2,000-hour vertical spin-on transmission filter
●	●	●	Transmission fill tube and sight gauge
▲	●	●	Front locking differential
▲	▲	▲	Rear locking differential
●	●	●	Transmission diagnostic ports
	●	●	5-speed transmission with lockup torque converter
●	▲	▲	5-speed transmission with non-lockup torque converter
▲	▲	▲	Automatic differential lock
▲	▲	▲	Wheel-spin control
			Quad-Cool™ Cooling System
●	●	●	Heavy-duty, trash-resistant radiator and high-ambient cooling package
●	●	●	2-side access to all coolers
●	●	●	Isolated from engine compartment
●	●	●	Engine radiator
●	●	●	Integral engine oil cooler
●	●	●	Hydraulic oil cooler (oil to air)
●	●	●	Transmission oil cooler (oil to air)
●	●	●	Charge air cooler (air to air)
●	●	●	Coolant recovery tank
●	●	●	Antifreeze, –37 deg. C (–34 deg. F)
●	●	●	Cool-on-demand, hydraulically driven, swing-out fan
●	●	●	Enclosed fan safety guard
▲	▲	▲	Automatic reversing fan drive
▲	▲	●	Axle and service-brake coolers

524	544	624	Hydraulics
●	●	●	Automatic return-to-dig bucket positioner
●	●	●	In-cab adjustable automatic boom-height kickout/return to carry
●	●	●	Reservoir with sight gauge and fill strainer
●	●	●	Hydraulic diagnostic ports
●	●	●	4,000-hour in-tank filter
●	●	●	2 function — joystick with F-N-R
▲	▲	▲	2 function — joystick with steering column F-N-R
▲	▲	▲	2 function — 2-lever fingertip controls and steering column F-N-R
▲	▲	▲	3 function — joystick with F-N-R and 3rd-function auxiliary lever
▲	▲	▲	3 function — 3-lever fingertip controls and steering column F-N-R
▲	▲	▲	Ride control, automatic with monitor-adjustable speed settings
			Steering Systems
●	●	●	Conventional steering wheel with spinner knob
			Electrical
●	●	●	Solid-state electrical power-distribution system
●	●	●	Lockable master electrical-disconnect switch
●	●	●	Battery-terminal safety covers
●	●	●	By-pass start safety cover at starter
●	●	●	Pre-wired for beacon/strobe light
●	●	●	Lights: Halogen driving lights with guards (2) / Front (4) and rear (2) cab work lights / Turn signals and flashers / LED stop- and taillights
▲			Lights: Halogen driving lights with guards (2) / Front cab work lights (2) and rear (2) / Turn signals and flashers / LED stop- and taillights
▲	▲	▲	Heavy-duty front LED turn signal and marker lights
●	●	●	Programmable courtesy lights
●	●	●	Horn, electric
●	●	●	Reverse warning alarm
●	●	●	Multi-function/multi-language LCD color monitor includes: Digital instruments — Analog display (hydraulic oil temperature, engine coolant temperature, transmission oil temperature, and engine oil pressure) / Digital display (engine rpm, transmission gear/direction indicator, hour meter, fuel level, speedometer, and odometer)
●	●	●	Indicator lights: Standard and selected options / Amber caution and red stop
●	●	●	Operator-warning messages

While general information, pictures, and descriptions are provided, some illustrations and text may include product options and accessories NOT AVAILABLE in all regions, and in some countries products and accessories may require modifications or additions to ensure compliance with the local regulations of those countries.

Actual machine configuration may differ from image. Not all models available in all countries.

Net engine power is with standard equipment including air cleaner, exhaust system, alternator, and cooling fan at test conditions per ISO 9249. No derating is required up to 3050-m (10,000 ft.) altitude. Specifications and design subject to change without notice. Specifications with the exception of bucket capacity are in accordance with all applicable ISO standards. Except where otherwise noted, these specifications are based on units with applicable linkage and standard equipment, ROPS cab, rear cast bumper/counterweight, transmission side-frame guards, bottom guards, standard tires, full fuel tank, and 79-kg (175 lb.) operator.

Additional equipment *(continued)*

Key: ● Standard ▲ Optional or special See your John Deere dealer for further information.

524	544	624	Electrical <i>(continued)</i>
●	●	●	Built-in diagnostics: Diagnostic-code details / Sensor values / Calibrations / Individual circuit tester
▲	▲	▲	Electrical corrosion-prevention package
▲	▲	▲	AM/FM/Weather-Band (WB) radio
●	●	●	24- to 12-volt, 8-amp converter
Operator's Station			
●	●	●	Quiet Cab with air conditioning/heater
●	●	●	Keyless start with multiple security modes
●	●	●	Sealed-switch module with function indicators
●	●	●	Seat with deep foam, fabric cover, and adjustable air suspension
●	●	●	Seat with backrest extension, deep foam, fabric cover, and adjustable air suspension
●	●	●	Hydraulic controls integrated to seat
●	●	●	Seat belt, 76 mm (3 in.), with retractor
●	●	●	Cup holders (2)
●	●	●	Lunch-box/cooler holder
●	●	●	Dome and reading light
●	●	●	12-volt power port
●	●	●	Rubber floor mat
●	●	●	Tilt steering column
●	●	●	Operator's manual storage compartment
●	●	●	Outside (2) and inside (1) rearview mirrors
●	●	●	Left-side operator-station access
●	●	●	Slip-resistant steps and ergonomic handholds
●	●	●	Sun visor
●	●	●	Front and rear intermittent windshield wiper and washers
▲	▲	▲	Beacon bracket
▲	▲	▲	Rear camera
▲	▲	▲	Rear camera with radar object-detection system
●	●	●	LOADRITE™ L2180™ Payload Scale Ready
Loader Linkage			
●	●	●	Z-Bar loader linkage
▲	▲	▲	High-lift Z-Bar loader linkage

524	544	624	Buckets and Attachments
●	●	●	Full line of Deere pin-on buckets
▲	▲	▲	Full line of Deere hook-on buckets and forks
Overall Vehicle			
●	●	●	JDLINK™ Ultimate wireless communication system (available in specific countries; see your dealer for details)
●	●	●	NeverGrease™ rear-axle oscillation
▲	▲	▲	NeverGrease steering cylinders
●	●	●	Front and rear tie-downs
●	●	●	Rear cast bumper with rear hitch and locking pin
●	●	●	Articulation locking bar
●	●	●	Loader boom service locking bar
●	●	●	40-deg. steering articulation to each side with rubber-cushion stops on frame
●	●	●	Vandal protection with lockable engine enclosures, right counterweight storage, battery box, and filler access for radiator/fuel/hydraulic transmission
●	●	●	Left-side service steps and handholds
●	●	●	Storage compartment
●	●	●	Fuel-tank fill strainer
●	●	●	Heavy-duty fuel-tank guard
●	●	●	Ground-level fueling
●	●	●	Same-side ground-level daily servicing
●	●	●	20.5-25 L3 16 PR tires on 3-piece rims
▲			17.5-25 L3 16 PR tires on 3-piece rims
●	●	●	Environmental drains for engine, transmission, hydraulic oils, and engine coolant
●	●	●	Fluid-sampling ports for engine, transmission, hydraulic and axle oils, and engine coolant
●	●	●	Fenders, front
▲	▲	▲	Fender, full-coverage, front
▲	▲	▲	Fenders, full-coverage, front and rear
▲	▲	▲	Transmission side-frame guards
▲	▲	▲	Bottom guards, front frame and transmission
▲	▲	▲	Lift eyes

While general information, pictures, and descriptions are provided, some illustrations and text may include product options and accessories NOT AVAILABLE in all regions, and in some countries products and accessories may require modifications or additions to ensure compliance with the local regulations of those countries.

Actual machine configuration may differ from image. Not all models available in all countries.

Net engine power is with standard equipment including air cleaner, exhaust system, alternator, and cooling fan at test conditions per ISO 9249. No derating is required up to 3050-m (10,000 ft.) altitude. Specifications and design subject to change without notice. Specifications with the exception of bucket capacity are in accordance with all applicable ISO standards. Except where otherwise noted, these specifications are based on units with applicable linkage and standard equipment, ROPS cab, rear cast bumper/counterweight, transmission side-frame guards, bottom guards, standard tires, full fuel tank, and 79-kg (175 lb.) operator.



JOHN DEERE



While general information, pictures, and descriptions are provided, some illustrations and text may include product options and accessories **NOT AVAILABLE** in all regions, and in some countries products and accessories may require modifications or additions to ensure compliance with the local regulations of those countries.

JohnDeere.com