

NEW

# FARO FARO COMBILINE

PÖTTINGER multipurpose loader wagons with rotors





POTTINGER  
FARO COMBINE

POTTINGER

FARO  
4010 COMBINE

NEW HOLLAND

# Rotor-type loader wagons packed with the latest technology

## **Loader wagons for tractors from 90 to 150 hp**

PÖTTINGER presents the FARO 3510, 4010, 4510, 5010 and FARO 8010; the new models in the medium-capacity loader wagon segment ranging between 90 and 150 hp. The 31-knife knife bank and powerful rotor drive for higher capacity make the new FARO a high-performance loader wagon.

## **2 in 1 silage/harvesting combination**

The FARO 4010 COMBILINE can also be used as a harvest transport wagon, turning it into a cost-effective all-rounder.

## Contents

	Page
Drawbar / Frame / Bodywork / Driveline	4
Pick-up / Loading rotor / Chopping system	6
Automatic loading	10
Automatic unloading	12
Controller	14
Chassis / Tyres	16
Technical data / Equipment	18

All information on technical data, dimensions, weights, output, etc. is approximate and is not binding.

# Impressive construction



## Rugged drawbar

Depending on the type of tractor and the tyres fitted, a turning angle of up to 60° is possible thanks to the narrow design of the drawbar.

### Top or bottom mounting, 2.20 sh t / 2.0 t supported load

A pivoting draw bar with two double acting cylinders is fitted as standard. A drawbar shock absorber is available as an option.

### Practical equipment

- All hoses and cables are routed tidily through the hose holder.
- A folding support leg makes it easy to attach and detach.
- A ball hitch coupling is available as an option.
- Load-Sensing system is also available.



## Strong frame

The frame components are constructed using high quality QSTE fine-grained steel. Frame and side pillars are fastened using finely threaded bolts – no welds. Closely-spaced pillars and high-strength side profiles ensure the highest strength.

- Clear inside width of 6.88" / 2.10 m.
- On D models, the tailgate opening angle can be adjusted as required from the tractor seat.
- Access ladder and side door are standard on D models, optional on L models.
- Floodlights for loading chamber and work area available as an option.





Power transfer up to 1600 Nm  
17% higher capacity

**The driveline is designed for high outputs. FARO loader wagons are designed for use on tractors up to 150 hp.**

They are driven by a wide-angle PTO shaft and a cam-type clutch to protect the driveline.

- High torque protection of 1600 Nm.
- High performance power range from 90 to 150 hp.
- Loading rotor driven by 1 1/2 inch high strength simplex chain.
- Automatic chain tensioner.
- Automatic chain lubrication for loading system and pick-up



## Scraper floor drive system

A strong hydraulic motor provides the drive for the scraper floor, the speed of which can easily be controlled. A two speed motor is also available as an option.



## Beater rotor drive transmission

The driveline to the beater rotors is concealed within the frame. The strong drive shaft is protected by a cam clutch at 1200 Nm.

# Pick-up

High performance with 6 rows of tines

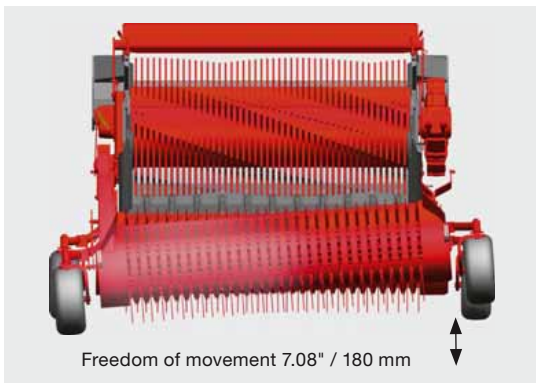

## Floating pick-up for maximum intake

The PÖTTINGER pick-up guarantees maximum feed rate. The transfer zone from the pick-up tines to the rotor has been optimised and adapted. The Pöttinger floating pick-up, with six rows of tines, delivers impressive performance. A reliable and high intake pick-up is still achieved at high forward speeds and in difficult harvest conditions.

### Best ground tracking

Two jointed support arms ensure the pick-up has complete freedom of movement. A spring alleviates the pick-up weight so less pressure is exerted on the ground. To ensure perfect ground tracking and cornering, the 16 x 6.5-8 jockey wheels can be adjusted to ensure they make contact with the ground on precisely the same line as the tines.

- Unique travel of 7.08" / 180 mm for perfect ground tracking and exact contouring.
- Trailed jockey wheels are available as an option; they are standard on the FARO 8010.
- Automatic pick-up reel switch off on FARO D models with beaters.
- An additional tracking roller is available as an option.

### Perfect forage flow

An optimised wind guard with swath roller and guide plates ensure perfect forage flow with every type of crop, even at high loading speed.



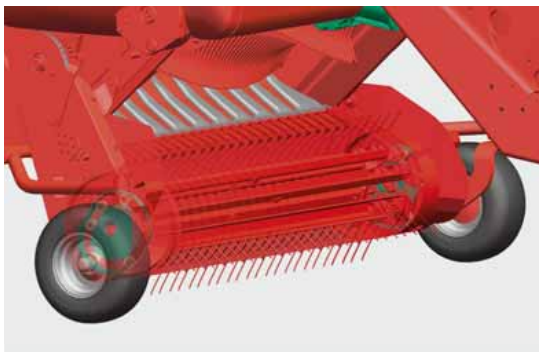

## Controlled pick-up for clean forage

The sealed twin-race roller bearings on the cam rollers are designed to withstand high stresses. The pick-up tines are controlled in a sweeping arc. This results in optimum protection of the sward, lower levels of soil contamination and prevents unnecessary wear to the tines.

- The pickup is controlled from both ends by a steel cam track.
- Because the pick-up controls the movement of the tines, the crop is brought closer to the rotor tines which is a real advantage with short, wet grass in the autumn.

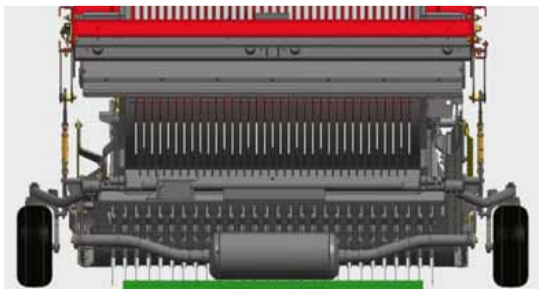

## Additional tracking roller behind pick-up

This newly developed additional tracking roller is located behind the middle of the pick-up on PÖTTINGER loader wagons. Being located in the centre prevents it from sinking into tractor wheel marks and as a result guarantees perfect ground tracking and clean forage.

### **The Parallelogram makes all the difference**

The parallelogram guide linkage ensures 100% freedom of movement of the pick-up, which significantly improves contour tracking for clean forage, even in difficult conditions. The front jockey wheels are adjusted independently.

- The additional tracking roller is raised with the pick-up.
- Full ground clearance is still ensured.



# ROTOMATIC PLUS

## Loading and chopping



## Smooth running and fuel saving

ROTOMATIC PLUS is the heart of the FARO range. Rugged and powerful, the rotor delivers high output chopping and compression. ROTOMATIC PLUS stands for smooth, efficient chopping of the crop and perfect transfer from the pick-up.

- The loading rotor has seven rows of tines arranged in a spiral with a diameter of 29.52" / 750 mm.
- The loading rotor is mounted on self-aligning ball bearings at both ends.
- The bearings are located on the rotor frame between the rotor and transmission to protect the bearings and drive chain.

### Optimised tine geometry

The conveyor tines made from hardened Durostat 500 fine-grained steel are 0.27" / 7 mm thick and ensure maximum performance, even with short, wet forage. The optimised tine shape and large scraper surface ensure the best possible compression in the loading chamber. The tine rings are hooked into the central drum and welded around the circumference for exact positioning.

The scrapers have an 0.47" / 12 mm wide rear face and are individually mounted and bolted. They ensure highest possible compression, depending on how the automatic loading system is set.

## EASY MOVE – the original

A unique solution, originally by Pottinger. The EASY MOVE knife bank swings out alongside the wagon to ensure ease of use. Change knives conveniently at the side of the wagon.





## 31 knives for 1.77" / 45 mm short chop

### Best knife quality

The knives are produced from hardened tool steel and their pressed serrated edge ensures a precise chop. The extra thick rear edge of the knife guarantees an extended service life.

FARO 8010 – maximum of 11 knives.

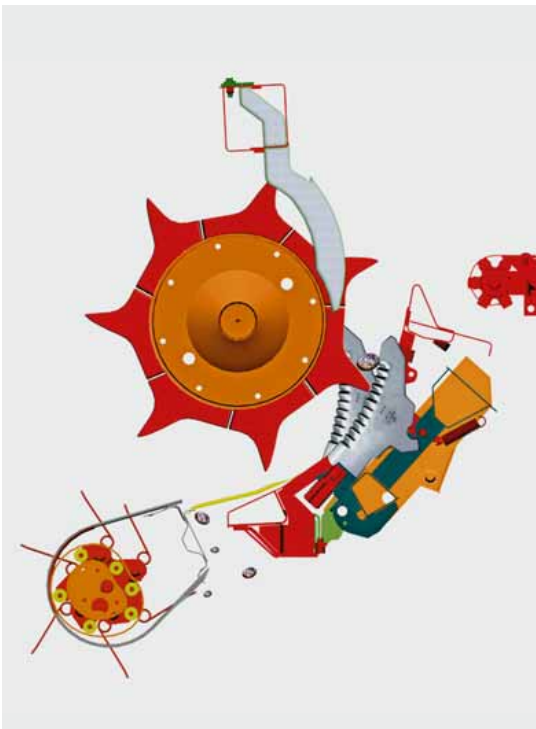

## Knife protection

PÖTTINGER protects the heart of the silage wagon with an innovative device: the patented foreign object protection system. This device ensures that each knife is individually protected from damage.

- High output requires an adapted trigger pressure. Powerful springs securely hold each individual knife in the correct position to ensure an even chop. Where Pöttinger stands out is that its trigger pressure for wagon knives reacts differently to a foreign object depending on its size.
- Smaller foreign bodies fall through between the pick-up and the rotor.
- Larger foreign bodies are pushed by the rotor onto the knife and move it briefly in the direction of rotation.
- The trigger roll at the back of the knife is lifted out of its holder and the knife releases the foreign body. The resistance is minimal when tripped, which protects the knife.
- After the object has passed through the chopping system, a spring pivots the knife back into its original position.

Unlike a harvester, this system does not pulverise stones. As a result, the cattle leave foreign objects in the trough, preventing injuries to the digestive system from ingestion.

# Versatile and productive



## Engineered bodywork

A key quality feature is the impact-resistant CIP powder coated finish. The powder coated topcoat has proved itself in the field thanks to its durability. Pottinger have used automotive specification paintwork since 1996.

- Smooth wall panels with a special coating ensure that the wagon is completely empty of forage after unloading.
- Close pillar spacing guarantees high strength.
- Easy access to the interior of the wagon is provided by means of an access ladder (optional on L the version).

### All-steel structure

- The extension bars can be adjusted by 4.72" / 120 mm or 8.26" / 210 mm to lower overall height.
- Optional roof profiles improve compression of hay and straw on the FARO 8010.

### Dry crop extension

A hydraulic folding dry crop extension is also available for FARO 3510/4010/4510 models. This reduces the maximum height to 9.71' / 2.96 m.

### Additional equipment options

- H3 floodlight inside loading chamber
- LED floodlights on front panel and mudguards.
- Video system with monitor and one or two cameras.
- Side and marker lights.
- Beacon light for loader wagon.



The automatic loading system guarantees that the wagon is filled to achieve maximum transport capacity. The forage is already carefully compressed in the transfer duct to make full use of the loading chamber. This is standard on the FARO 4010 COMBILINE and FARO 8010.

#### **Sensors mounted in front flap and upper panel section**

A sensor at the lower end of the front panel measures the loading pressure for damp, heavy grass and controls the scraper floor. This prevents the forage from being mashed due to excessive load on the loading rotor.

The second sensor in the forage compression flap measures the compression inside the loading chamber. The forage is compressed uniformly and the loading chamber filled to the optimum capacity.

## FARO 4010 COMBILINE

Roof ropes for a rear tarpaulin are available as an option for crop material with a low density.

The forage compression flap can be equipped with an optional hydraulic cylinder which can be controlled from the tractor seat. This enables a rapid change between pick up loading and top-fill loading.

### **1. Loader wagon mode**

In loader wagon mode, to allow the flow of the crop into the wagon, which is then regulated by the automatic loading system. the forage compression flap is folded upwards to allow the flow of the crop into the wagon, which is then regulated by the automatic loading system. Compression is adjustable so it can be set to ideally match the power of the tractor.

### **2. Harvest transport mode**

In harvest transport mode, the compression flap is folded inwards as no crop is being picked up. The optional loading duct cover prevents crop from falling into the rotor duct. Whilst slanting mudguards and smooth structural beams prevent stray crop from being carried out onto the road.

# Unloading at the press of a button



## Automatic unloading

A press of a button on the terminal is all that is needed and the full cross section of the tailgate opens to unload FARO L and D models in a few minutes. The automatic unloading system makes life easier for the driver and protects the machine.

## Lowered scraper floor

- The scraper floor has been lowered at the front by 5.90" / 150 mm to accommodate tyres up to 710/35 R 22,5.
- The forage is pushed upwards as it moves to the rear. This ensures smooth, uniform unloading with a low power requirement.
- Powerful drive chains ensure rapid unloading.
- A two-stage motor is available as an option for unloading speeds of up to 59.05'/min / 18 metres/min.



### Longevity of scraper floor

The PÖTTINGER scraper floor guarantees long term reliability.

The load chamber floor is constructed of pressure treated, durable wood.

The tongue and groove boards are bolted to the frame whilst two sets of hardened slats run offset to each other along the wagon floor. These slats, and the greasing points for the floor shafts are easily accessed at the side of the wagon.



### Load sensing

All PÖTTINGER loader wagons are load sensing compatible. The required oil flow rate is precisely measured and adjusted to demand. This prevents the oil from heating up and saves power by up to 15 kW / 20 hp.



## Metering on demand

### FARO D models

A uniformly distributed blanket of forage is essential for perfect compaction with two beater rotors guaranteeing perfect distribution. The aggressive tines deliver an impressive performance, even with highly compressed forage. Bars on the rotors also ensure that maize material can be unloaded effectively. A pressure sensor in the beater rotor bearings controls the scraper floor automatically.



### Multifunction tailgate

The tailgate opening angle can be set to different positions from the tractor seat to minimise the effects of crosswinds.

- Beater driveline protected to 1200 Nm.
- Automatic chain tensioner.
- Easy access central greasing point.
- Third beater rotor available as an option.

### Cross conveyor belt

The optional cross conveyor belt is 35.03" / 890 mm wide and is powered hydraulically.

- Runs to left and right.
- Tailgate locking system.
- Dedicated on-board hydraulics with flowrate of less than 17.59 gal / min / 80 l/min.
- Remote control using optional WIRELESS POWER CONTROL.



# Perfectly controlled



These operator terminals provide the tractor driver with a well deserved level of support to ensure efficient and consistent productivity. PÖTTINGER'S new generation of in-cab terminals make sure you have everything under control, even after a long day in the field. The development of the terminal focussed on maximum operating convenience, ergonomics and automation of each working step. The intuitive layout is especially useful if there is a frequent change of drivers. The result is a range of control systems to suit your equipment, from electronic preselect controls through to fully integrated ISOBUS terminals.

### Tough and illuminated – ready to work day and night

- Heavy duty 2-component synthetic casing with rubber edge guard.
- All units feature an illuminated graphic display.
- Raised back-lit keys for optimum visibility at night.

Terminals	DIRECT CONTROL	POWER CONTROL	POWER CONTROL Wireless	ISOBUS Terminal CCI 100
FARO 4010 L COMBILINE	■	□	□	□
FARO 4010 D COMBILINE	-	■	□	□
FARO 3510 L	□	□	□	□
FARO 3510 D	-	■	□	□
FARO 4010 L	■	□	□	□
FARO 4010 D	-	■	□	□
FARO 4510 L	■	□	□	□
FARO 4510 D	-	■	□	□
FARO 5010 L	■	□	□	□
FARO 5010 D	-	■	□	□
FARO 8010 L	■	□	□	□

■ = Standard, □ = Option



## Control terminals

### **DIRECT CONTROL**

All functions can be selected directly on wagons without unloading beaters. The brightness of the graphic display and illuminated keys is adjustable.

### **POWER CONTROL**

All functions are controlled directly from the terminal. Error messages are also displayed. There is integrated data logging.

- Automatic functions for loading and unloading.
- Ergonomic layout of control keys.
- Background-lighting

### **POWER CONTROL Wireless**

For convenient operation of the loader wagon, including from outside the tractor cab.

- Specially for operating the cross conveyor belt.
- A carry-belt keeps both hands free.
- Wide range of up to 328" / 100 m.



### **CCI 100 terminal 100 % ISOBUS**

A universal control terminal, compatible with all ISOBUS machines from Pottinger and other machinery manufacturers, is also available.

- High quality 8.4" TFT colour screen with back-lit keys.
- Touchscreen, automatic functions for loading and unloading.
- USB interface, M 12x1 camera connection.



# Chassis & Tyres



## **Suspended tandem axle with parabolic springs, 11.57 sh t / 10.5 t axle load, 17" (1) standard on FARO 3510 / 4010.**

Nine large parabolic springs, spaced 43,30" / 1100 mm apart, provide the necessary suspension to reduce compression on the ground. The compensating linkage distributes the pressure exerted on the ground evenly between the two axles.

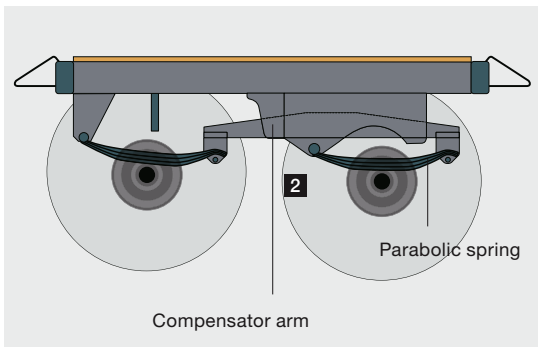

## **Tandem axles with parabolic leaf spring suspension, 14.32 sh t / 13 t axle load, 17" (2) standard on FARO 4510 / 5010. 22.5" standard on FARO 4010 COMBILINE.**

Parabolic springs with large spring-to-axle spacing and compensator arm prevents swaying.

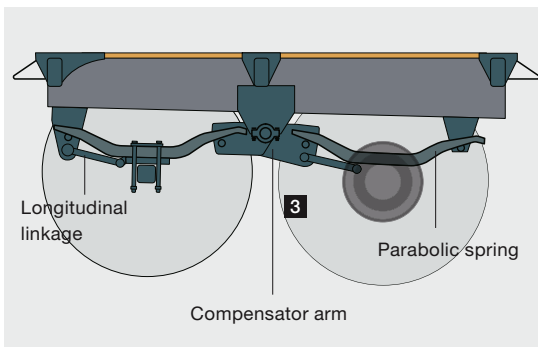

## **Tandem axles with parabolic spring suspension and longitudinal linkage, 17.63 sh t / 16 t axle load, 22,5" (3)**

Compensator arm prevents swaying while strong trailing linkages apply the braking and steering force. This ensures smooth running in the field and on the road as well as perfect suspension when unloading in the clamp.

### **Trailed steering axle optional**

No damage to sward, even with really heavy loads. The ISOBUS terminal automatically locks the trailed steering axle at high driving speeds and when reversing.

## **Tandem axles with hydro-pneumatic suspension and trailed steering axle, 17.63 sh t / 16 t axle load, 22,5"**

The large axle compensation of up to 8.66" / 220 mm is designed to handle challenging field entrances and poor track conditions.

### **Pneumatic brakes**

The four wheel air brake system with automatic load-dependent braking system (ALB) ensures safe and smooth braking at high speed.

### **Hydraulic brakes**

Hydraulic brakes can be supplied dependent on local legislation.





FARO	4010 L / D	3510 L / D	4010 L / D	4510 L / D	5010 L / D	8010 L
	<b>COMBILINE</b>					
High drawbar, supported load 2.2 sh t / 2 t	■	■	■	■	■	■
Low drawbar, supported load 2.2 sh t / 2 t	□	□	□	□	□	□
Rotating eye	□	□	□	□	□	□
Ball hitch	□	□	□	□	□	□
Drawbar shock absorber	□	□	□	□	□	□
Tandem axle leaf springs 11.57 sh t / 10.5 t axle load, 17"	-	■	■	-	-	-
Pparabolic springs 14.32 sh t / 13 t axle load, 17"	-	□	□	■	■	■
Pparabolic springs ADR 14.33 sh t / 13 t axle load, 22,5"	■	-	□	□	□	□
Parabolic springs BPW 17.63 sh t / 16 t axle load, 22,5"	□	-	□	□	□	□
Hydro-pneumatic suspension ADR 17.63 sh t / 16 t axle load, 22,5"	□	-	□	□	□	□
Jockey steering axle	□	-	□	□	□	□
Permissible total weight 13,77 sh t / 12.5 t	-	■	■	-	-	-
Permissible total weight 16.53 sh t / 15 t	■	□	□	■	■	■
Permissible total weight 19.84 sh t / 18 t	□	-	□	□	□	-
Tyres 500/50-17	-	■	■	■	■	■
Tyres 520/50 R 17	-	□	□	□	□	□
Tyres 560/45 R 22,5	■	-	□	□	□	□
Tyres 620/40 R 22,5	□	-	□	□	□	□
Tyres 710/35 R 22,5	□	-	□	□	□	□

■ = Standard, □ = Option

# Technical data



	<b>FARO 3510 L</b>	<b>FARO 3510 D</b>	<b>FARO 4010 L</b>	<b>FARO 4010 D</b>
Capacity cu ft / m <sup>3</sup>	1236 / 35	1236 / 35	1412 / 40	1412 / 40
Volume DIN with roof ropes cu ft / m <sup>3</sup>	847 / 24	847 / 23	953 / 27	918 / 26
Pickup width ft / m	6.07 / 1.85	6.07 / 1.85	6.07 / 1.85	6.07 / 1.85
Number of knives	31	31	31	31
Knife spacing inch / mm	1.77 / 45	1.77 / 45	1.77 / 45	1.77 / 45
Loading area length ft / m	16.4 / 5.0	15.58 / 4.75	18.64 / 5.68	17.81 / 5.43
Loading area width ft / m	6.89 / 2.1	6.89 / 2.1	6.89 / 2.1	6.89 / 2.1
Length ft / m	25.52 / 7.78	27.07 / 8.25	27.76 / 8.46	29.30 / 8.93
Width ft / m	7.94 / 2.42	7.94 / 2.42	7.94 / 2.42	7.94 / 2.42
Height with roof ropes 17" ft / m	11.68 / 3.56	11.68 / 3.56	11.68 / 3.56	11.68 / 3.56
Height with roof ropes 22.5" ft / m	–	–	12.07 / 3.68	12.07 / 3.68
Standard weight lbs / kg	6.12 / 5.55	6.56 / 5.95	6.23 / 5.65	6.67 / 6.05

	<b>FARO 4010 L COMBILINE</b>	<b>FARO 4010 D COMBILINE</b>
Capacity ft / m <sup>3</sup>	1412 / 40	1412 / 40
Volume DIN without roof ropes cu ft / m <sup>3</sup>	812 / 23	777 / 22
Volume DIN with roof ropes cu ft / m <sup>3</sup>	865 / 24,5	830 / 23,5
Pickup width ft / m	6.07 / 1.85	6.07 / 1.85
Number of knives	31	31
Knife spacing inch / mm	1.77 / 45	1.77 / 45
Loading area length ft / m	18.64 / 5.68	18.64 / 5.68
Loading area width ft / m	6.89 / 2.1	6.89 / 2.1
Length ft / m	27.56 / 8.4	29.13 / 8.88
Width ft / m	8.23 / 2.51	8.23 / 2.51
Height without roof ropes 22,5" ft / m	10.99 / 3.35	10.99 / 3.35
Height with roof ropes 22,5" ft / m	12.57 / 3.675	12.57 / 3.675
Standard weight sh t / t	6.7 / 6.35	7.77 / 6.85



<b>FARO 4510 L</b>	<b>FARO 4510 D</b>	<b>FARO 5010 L</b>	<b>FARO 5010 D</b>	<b>FARO 8010 L</b>
1588 / 45	1588 / 45	1765 / 50	1765 / 50	2824 / 80
1059 / 30	1023 / 29	1165 / 33	1129 / 32	1695 / 48
6.07 / 1.85	6.07 / 1.85	6.07 / 1.85	6.07 / 1.85	6.07 / 1.85
31	31	31	31	11
1.77 / 45	1.77 / 45	1.77 / 45	1.77 / 45	1.77 / 45
20.87 / 6.36	20.05 / 6.11	20.87 / 6.36	20.05 / 6.11	24.05 / 7.73
6.89 / 2.1	6.89 / 2.1	6.89 / 2.1	6.89 / 2.1	6.89 / 2.1
29.99 / 9.14	29.99 / 9.14	29.99 / 9.14	31.53 / 9.61	35.40 / 10.79
7.94 / 2.42	7.94 / 2.42	7.94 / 2.42	7.94 / 2.42	8.20 / 2.5
11.68 / 3.56	11.68 / 3.56	12.34 / 3.76	12.34 / 3.76	13.58 / 3.98
12.07 / 3.68	12.07 / 3.68	12.73 / 3.88	12.73 / 3.88	13.45 / 4.1
6.39 / 5.8	6.83 / 6.2	6.45 / 5.85	7.0 / 6.35	7.22 / 6.55

# FARO equipment options



**POWER CONTROL**



**POWER CONTROL  
Wireless**



**CCI ISOBUS  
Terminal**



**Additional tracking roller  
for pick-up**

FARO	POWER CONTROL	POWER CONTROL Wireless	CCI ISOBUS Terminal	Additional tracking roller for pick-up
3510 L / 4010 L / 4510 L	<input type="checkbox"/>	<input type="checkbox"/>	<input type="checkbox"/>	<input type="checkbox"/>
3510 D / 4010 D / 4510 D	<input checked="" type="checkbox"/>	<input type="checkbox"/>	<input type="checkbox"/>	<input type="checkbox"/>
5010 L	<input type="checkbox"/>	<input type="checkbox"/>	<input type="checkbox"/>	<input type="checkbox"/>
5010 D	<input checked="" type="checkbox"/>	<input type="checkbox"/>	<input type="checkbox"/>	<input type="checkbox"/>
8010 L	<input type="checkbox"/>	<input type="checkbox"/>	<input type="checkbox"/>	<input type="checkbox"/>



**Crop deflector board  
for steel superstructure**



**Dry crop extension  
folds hydraulically**



**Access door with ladder**



**3rd beater rotor**

FARO	Crop deflector board for steel superstructure	Dry crop extension folds hydraulically	Access door with ladder	3rd beater rotor
3510 L / 4010 L / 4510 L	<input type="checkbox"/>	<input type="checkbox"/>	<input type="checkbox"/>	-
3510 D / 4010 D / 4510 D	<input type="checkbox"/>	<input type="checkbox"/>	<input checked="" type="checkbox"/>	<input type="checkbox"/>
5010 L	<input type="checkbox"/>	-	<input type="checkbox"/>	-
5010 D	<input type="checkbox"/>	-	<input checked="" type="checkbox"/>	<input type="checkbox"/>
8010 L	<input type="checkbox"/>	-	-	-

■ = Standard, □ = Option



**Knife bank swings out alongside wagon**



**Bolt-on frame with 6 / 11 knives**



**Automatic loading**



**Metal roof profiles**



**Adjustable tailgate strut**

<input type="checkbox"/>	<input type="checkbox"/>	<input type="checkbox"/>	-	<input type="checkbox"/>
<input type="checkbox"/>	<input type="checkbox"/>	<input type="checkbox"/>	-	-
<input type="checkbox"/>	<input type="checkbox"/>	<input type="checkbox"/>	-	<input type="checkbox"/>
<input type="checkbox"/>	<input type="checkbox"/>	<input type="checkbox"/>	-	-
-	■ / <input type="checkbox"/>	■	<input type="checkbox"/>	-



**Cross conveyor belt**



**On-board hydraulics for cross conveyor belt**

-	-
<input type="checkbox"/>	<input type="checkbox"/>
-	-
<input type="checkbox"/>	<input type="checkbox"/>
-	-

**Additional equipment options**

- Trailed jockey wheels for pick-up
- Hydraulic pick-up weight alleviation
- Rear switch for scraper floor
- Load sensing
- Two-stage motor for scraper floor
- Hydraulic brake
- Loading chamber and work lights
- Marker lights
- Video system with monitor and camera
- Rotating light for loader wagons

# FARO 4010 COMBILINE equipment options



**POWER CONTROL**



**POWER CONTROL  
Wireless**



**CCI ISOBUS  
Terminal**



**Additional tracking roller  
for pick-up**

**FARO**

	POWER CONTROL	POWER CONTROL Wireless	CCI ISOBUS Terminal	Additional tracking roller for pick-up
4010 L COMBILINE	<input type="checkbox"/>	<input type="checkbox"/>	<input type="checkbox"/>	<input type="checkbox"/>
4010 D COMBILINE	<input checked="" type="checkbox"/>	<input type="checkbox"/>	<input type="checkbox"/>	<input type="checkbox"/>



**Access door with ladder**



**Cross conveyor belt**



**On-board hydraulics for  
cross conveyor belt**



**Folding rotor duct cover**

**FARO**

	Access door with ladder	Cross conveyor belt	On-board hydraulics for cross conveyor belt	Folding rotor duct cover
4010 L COMBILINE	<input type="checkbox"/>	-	-	<input type="checkbox"/>
4010 D COMBILINE	<input checked="" type="checkbox"/>	<input type="checkbox"/>	<input type="checkbox"/>	<input type="checkbox"/>

■ = Standard, □ = Option



**Knife bank swings out alongside wagon**



**Bolt-on frame with 6 / 11 knives**



**Automatic loading**



**Roof ropes with rear tarpaulin**



**Hydraulic folding automatic loading flap**

**Additional equipment options**

- Trailed jockey wheels for pick-up
- Hydraulic pick-up weight alleviation
- Rear switch for scraper floor
- Load sensing
- Two-stage motor for scraper floor
- Hydraulic brake
- Loading chamber and work lights
- Outline marker and demarcation lights
- Video system with monitor and camera
- Rotating light for loader wagons



# PÖTTERPRO

**Your machine goes online.**

All the information on your machine  
**easily – anytime – anywhere**

Simply scan the QR code on the **data plate** with your smartphone or tablet or enter your machine number at [www.poettinger.at/poetpro](http://www.poettinger.at/poetpro). You will immediately receive all the information on your machine.

- Operating instructions
- Optional equipment information
- Brochures
- Photos and videos



# Original *inside* **24** hours service

## **PÖTTER Spare parts service**

- Worldwide network of sales and service partners.
- Decades of spare and wear parts availability.
- Original PÖTTER parts can be ordered online around the clock.

### **PÖTTER Landtechnik GmbH**

Industriegelände 1  
4710 Grieskirchen  
Austria  
Phone +43 7248 600-0  
Fax +43 7248 600-2513  
[info@poettinger.at](mailto:info@poettinger.at)  
[www.poettinger.at](http://www.poettinger.at)

### **POETTINGER US, Inc.**

393 Pilot Drive  
Valparaiso, IN 46383  
USA  
Phone +1 219 510-5534  
Fax + 1 219 707-5412  
[sales.us@poettinger.us](mailto:sales.us@poettinger.us)  
[www.poettinger.us](http://www.poettinger.us)

### **Importer for New Zealand:**

**Origin Agroup**  
PO Box 673, 57 Hautapu Road  
Cambridge  
New Zealand  
Phone +64 7 823 7582  
[info@originagroup.co.nz](mailto:info@originagroup.co.nz)  
[www.originagroup.co.nz](http://www.originagroup.co.nz)

### **Alois PÖTTER UK Ltd.**

15 St Marks Road, Corby  
Northamptonshire,  
NN18 8AN  
United Kingdom  
Phone + 44 1536 272 220  
[info.uk@pottingeruk.co.uk](mailto:info.uk@pottingeruk.co.uk)  
[www.pottingeruk.co.uk](http://www.pottingeruk.co.uk)

### **POETTINGER Australia PTY LTD**

15 Fordson Road  
Campbellfield, VIC 3061  
Australia  
Phone +61 3 9359 2969  
[sales.au@poettinger.com.au](mailto:sales.au@poettinger.com.au)  
[www.poettinger.com.au](http://www.poettinger.com.au)

### **Importer for South Africa:**

**VALTRAC**  
Cnr. Water & Buiten Street  
9585 Parys  
South Africa  
Phone +27 56 817 7338 7308  
[wynn@valtrac.co.za](mailto:wynn@valtrac.co.za)  
[www.valtrac.co.za](http://www.valtrac.co.za)

### **POETTINGER Canada Inc.**

650, Route 112  
St-Cesaire, PQ J0L 1T0  
Canada  
Phone +1 450 469 5594  
Fax +1 866 417 1683  
[sales.canada@poettinger.ca](mailto:sales.canada@poettinger.ca)  
[www.poettinger.ca](http://www.poettinger.ca)

### **POETTINGER Ireland Ltd.**

Industrial Estate  
Cashel Rd., Clonmel, Co. Tipperary  
Ireland  
Phone +353 52 6125766  
[info.ie@poettinger.at](mailto:info.ie@poettinger.at)  
[www.poettinger.ie](http://www.poettinger.ie)

